



川源（中国）机械有限公司
GSD Industrial Co.,Ltd.



SAR

表面式曝气机

SAR surface aerator

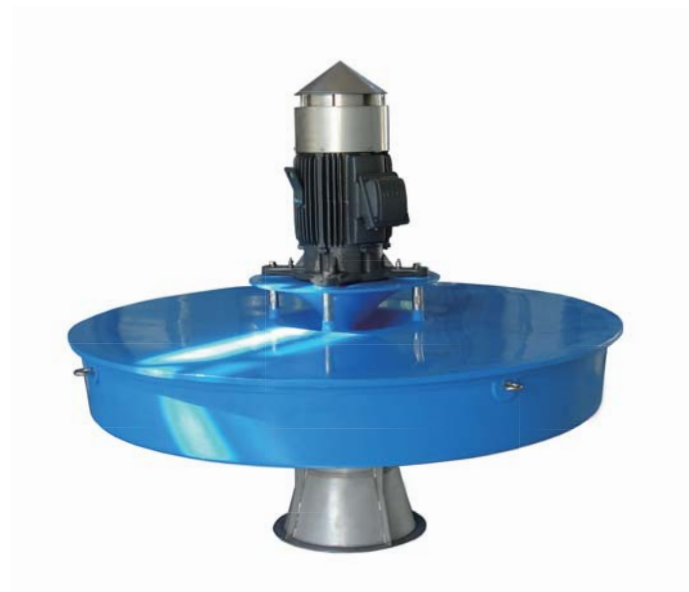

SAR 表面式曝气机

SAR Surface aerator

用途

表面曝气机乃是利用马达直接带动轴流式叶轮，将废水由导管经导水板向四周喷出并形成一薄片（或水滴状）的水幕，在飞行途中和空气接触形成水滴，在落下时撞击液面，液面产生乱流及大量的气泡，使水中含氧增加。本机系将池底的水吸上而由上方送出，形成一循环水流，故兼有搅拌的效果，适用于生活污水，农牧养殖供氧及其他各种工业污水曝气等。

简介

此高速曝气机产品系列，经设计可使曝气设备的两个最重要的功能最佳化——传输氧气和混合废水。废水经抽送通过曝气机，形成最佳的喷流形态，有利于氧气进入废水中。同时，这种废水抽送在池中形成了一定的水流速度，确保了池水的混合和氧气的扩散效果。设计和应用机械曝气设备的多年经验，结合我们广泛研究测试设备的自主能力，使提供给客户的高速曝气机不仅有最佳的传输氧气和混合废水的性能，同时达到这些性能的方式最经济、可靠。

曝气机选型

下图可用于快速估计所需功率。

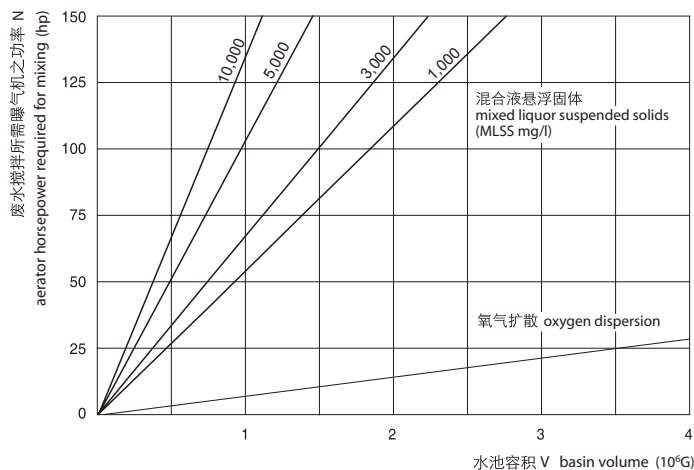

Applications

The GSD surface aerator (SAR) uses the motor to drive axial flow type impeller directly in order to pump waste water for creating the spray pattern (or water drop) through the water guide panel. When water contacts air, it will become water drops, which fall to the water surface and form the turbulence and bubbles. These bubbles will improve oxygen dispersion and increase oxygen in water. The GSD SAR device pumps water from the bottom to the top and creates circulation flows and stir processes. It is suitable for domestic waste water treatment, agriculture and aquaculture oxygen supply and other industrial waste water aeration.

Introduction

The high speed aerator line is designed to maximize the two most important functions of any aeration device—oxygen transfer and mixing of waste. The waste liquid is pumped through the unit in a manner which creates the most advantageous spray pattern for introducing oxygen into the liquid. At the same time, this pumping action creates a tank velocity pattern which insures the mixing of contents and thus the oxygen dispersion. Years of experience in the design and application of mechanical aeration equipment have been combined with the full capabilities of our extensive research test facility to provide a line of high speed aerators which not only maximize oxygen transfer and tank mixing characteristics but perform these functions in the most economical and reliable manner.

Aerator selection

The chart below may be used to make quick estimate of the horsepower required.

曝气机的传氧选型图

已知BOD(mg/l)及每日废水流量可利用下图选择废水处理所需曝气机之功率。使用时在图之左边选择需求之每日废水流量，然后延伸一水平线使与所需之BOD曲线相交，再由此引一垂直直线并读出在底部所需要之功率。

下图在以下条件下作得：废水BOD去除率90%，耗氧系数 α 为0.8，微生物每去除1磅BOD消耗氧1.25磅，本曝气机标准每马力小时传氧量为3.5磅。其准确度在10%以内。

Selection of aerators for O₂ transfer

This chart will help to select the required horsepower of aeration if the BOD (mg/l) and daily flow rate of wastewater are known. First, select the appropriate daily waste flow on the left side of the chart. Then extend a horizontal line to the right until you intersect the appropriate BOD curve. Drop a line vertically from the intersection to the bottom and read the horsepower required for aeration.

Calculations are based on a desired BOD reduction of 90%, α factor of 0.8, 1.25LB O₂/LB.BOD and a standard condition transfer of 3.5LB O₂/HP-HR. Accuracy is usually within 10%.

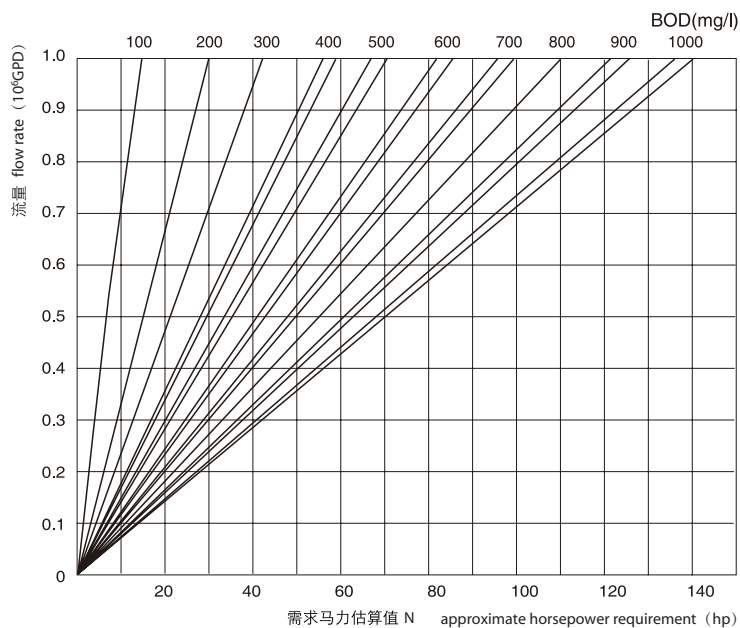

结构简图及材质 Construction and material

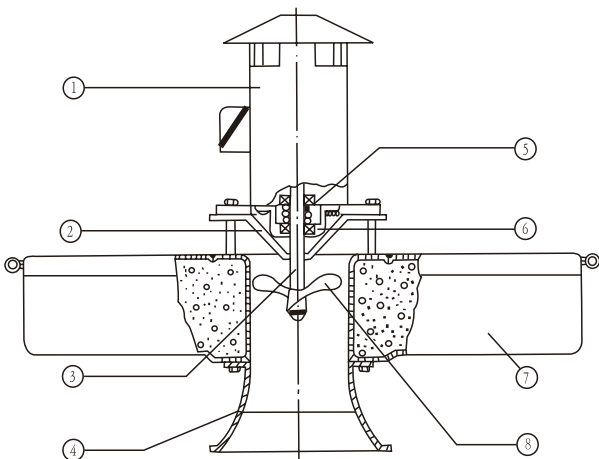

NO.	名称	Name	材质 Material	
			GB	JIS
1	马达	Motor	-	-
2	水流导板	Water guide panel	FRP	FRP
3	轴	Shaft	1Cr13	SUS410
4	进水导管	Water inlet pipe	HT200	FC200
5	机械轴封	Mechanical seal	-	-
6	轴封盖	Seal cover	HT250	FC250
7	浮筒	Floating	FRP	FRP
8	叶轮	Impeller	0Cr18Ni9	SUS304



结构概述

表面式曝气机包括马达，传动轴，直联式定速转动的轴流式叶轮及浮筒。浮筒将支撑所有必备之附件。

马达及轴：马达安装在水流喷射区的上方。马达为防水全封闭风扇冷却型，F级绝缘。3Ø，50HZ/60HZ。轴由不锈钢制成。

叶轮：叶轮由不锈钢制成。叶轮设计独特，叶片栅距设计确保在马达不过载的前提下能达到最大的水力传输。

浮体组合：浮体外壳由加强之玻璃纤维制成，浮体内填充高密度的聚氨酯泡沫塑料。系留孔可将张力在系留索间传递。

Construction summarization

Each aerator shall consist essentially of a motor, drive shaft, impeller directly driven at constant speed, and an integral flotation unit, which shall support the weight of certain accessories that may be added. All wetted metal parts shall be of corrosion resistant materials, and shall not require painting.

MOTOR AND SHAFT: The electric power unit is the heart of the machine, and is located above the high-density spray-diffusion zone to minimize its exposure to the nature and contents of the pumped liquid. The motors are Weatherproof Chemical Service, TEFC (Totally Enclosed Fan Cooled) 3 phase. These motors utilize a highly refined non-hygroscopic class B insulation system, in addition to which motor housing drains are provided to drain off internal condensation. Shaft is one piece from the upper bearing through the impeller.

IMPELLER: The impeller is constructed of stainless steel and is manufactured using the machined-pitch process which assures perfect impeller accuracy and top performance. The impeller pitch is designed for maximum hydraulic delivery without overloading the motor.

FLOATATION ASSEMBLY: The floatation hull is constructed of reinforced fibre-glass. The hull is completely filled with high-density closed cell polyurethane foam. The mooring eyes transfer tension from one mooring cable to another.

性能参数 Performance parameters

型号 Type	马达 Motor		曝气机 Aerator				
	功率 (hp)	转速 (r/min)	OC-HR (kg/h)	MD (m)	MZ (m)	D (m)	PR (m ³ /min)
SAR-32	2	1450	3.0	6	12	2~3	5
SAR-33	3	1450	4.2	9	18	3~4	7
SAR-35	5	1450	6.6	12	24	3~4	9
SAR-37	7 ¹ / ₂	1450	9.6	16	32	3~4	11
SAR-310	10	1450	11.5	19	38	3~4	19
SAR-315	15	1450	16.5	27	54	3~4	24
SAR-320	20	1450	21.0	32	64	3~4	29
SAR-325	25	1450	27.5	36	72	3~4	33
SAR-330	30	1450	31.0	40	80	3~4	37
SAR-340	40	1450	38.0	45	90	5~6	46
SAR-350	50	1450	50	50	100	5~6	55
SAR-360	60	1450	61	56	112	5~6	65
SAR-375	75	1450	73	62.5	125	5~6	80
SAR-3100	100	1450	95	70	140	5~6	120

MZ: 混合区域之直径(m)

OC-HR: 每小时传氧量(kg/h)

MD: 最低平均速度(大约1.2米/秒)时的安全混合直径(m)

D: 完全混合之深度，和MD相关

PR: 流量(m³/min)

MZ: Diameter of Mixing Zone. (m)

OC-HR: Kgs Oxygenation Capacity per Hour. (kg/h)

MD: Diameter of Complete Mixing in Meter at minimum average velocity of 1.2 meter per second (approx). (m)

D: Depth in Meter of Complete Mixing, related to MD.

PR: Pumping Rate, m³ per Minute.



外形及安装尺寸 Installation dimensions

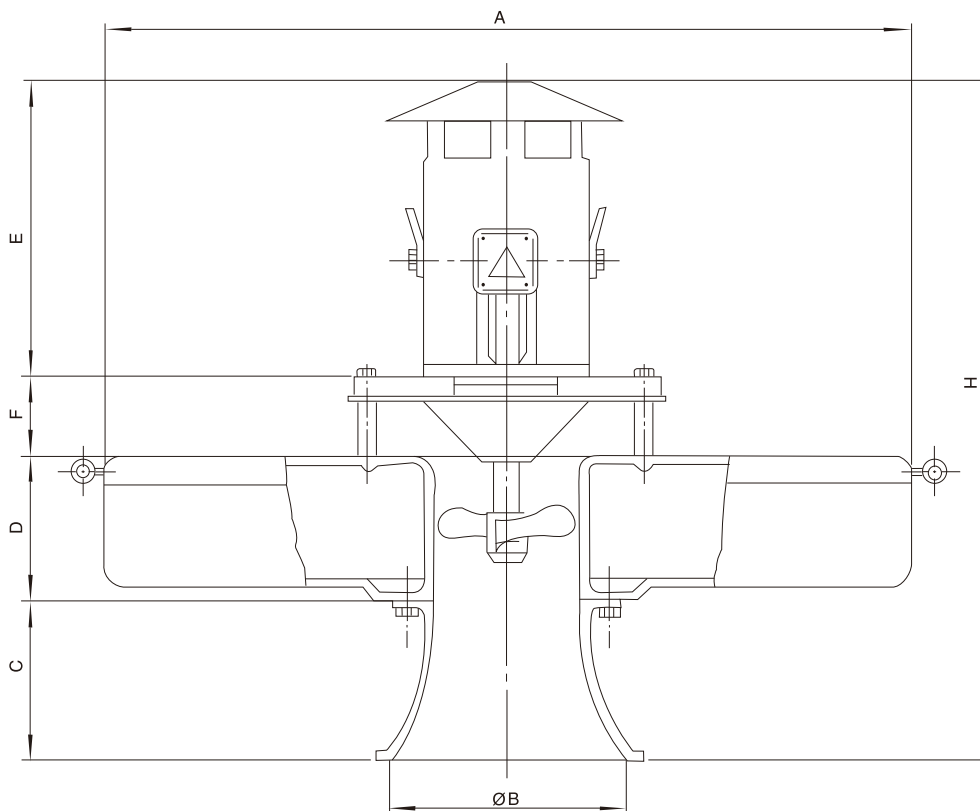

型号 Type	尺寸 Dimensions(mm)							
	A	B	C	D	E	F	H	W(kg)
SAR-32	1200	250	200	120	360	100	900	85
SAR-33	1200	250	200	120	360	100	900	90
SAR-35	1500	300	320	140	420	100	1120	130
SAR-37	1500	360	320	280	430	110	1140	160
SAR-310	1500	360	320	280	480	110	1190	180
SAR-315	1800	500	600	300	580	120	1600	250
SAR-320	1800	500	600	300	630	120	1650	290
SAR-325	1800	500	600	300	650	120	1670	350
SAR-330	1800	500	600	300	700	120	1720	390
SAR-340	1800	650	800	340	730	150	2020	430
SAR-350	1800	650	800	340	750	150	2040	430
SAR-360	2200	800	800	340	820	200	2160	720
SAR-375	2200	800	800	370	860	200	2230	795
SAR-3100	2200	800	800	400	950	200	2350	1075

安装方法 Installation method

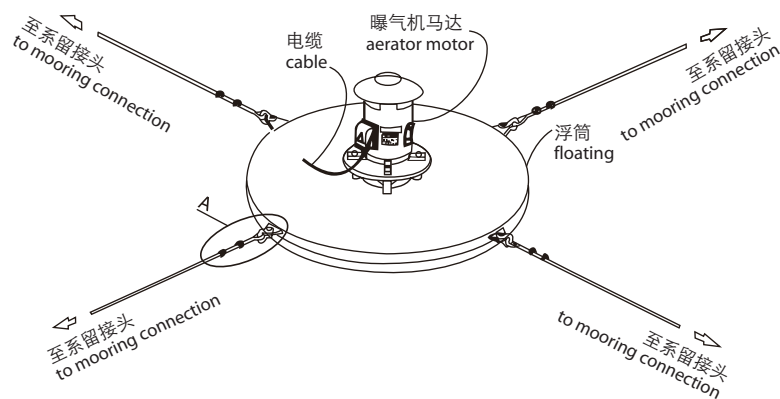

系留附件 Mooring accessories

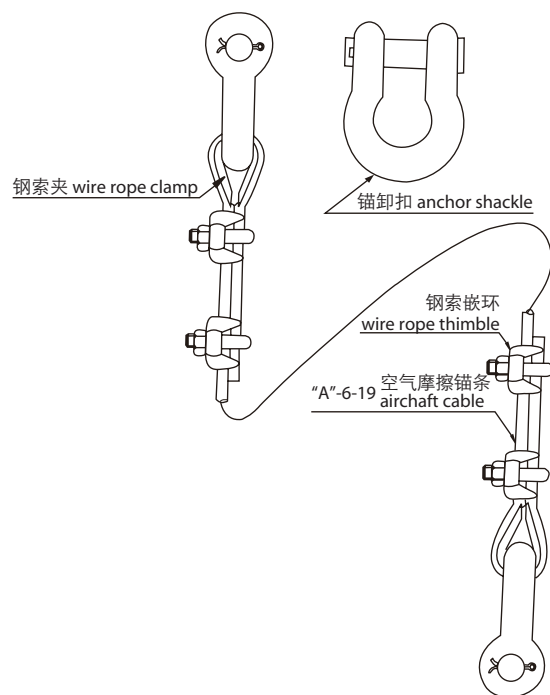

系留索规格 Mooring cable specifications

2~10	Ø 4mm	6 × 19	880KGS	SUS304
15~30	Ø 5mm	6 × 19	1380KGS	SUS304
40~100	Ø 6.3mm	6 × 19	2180KGS	SUS304

电缆选择图 Power cable selection chart

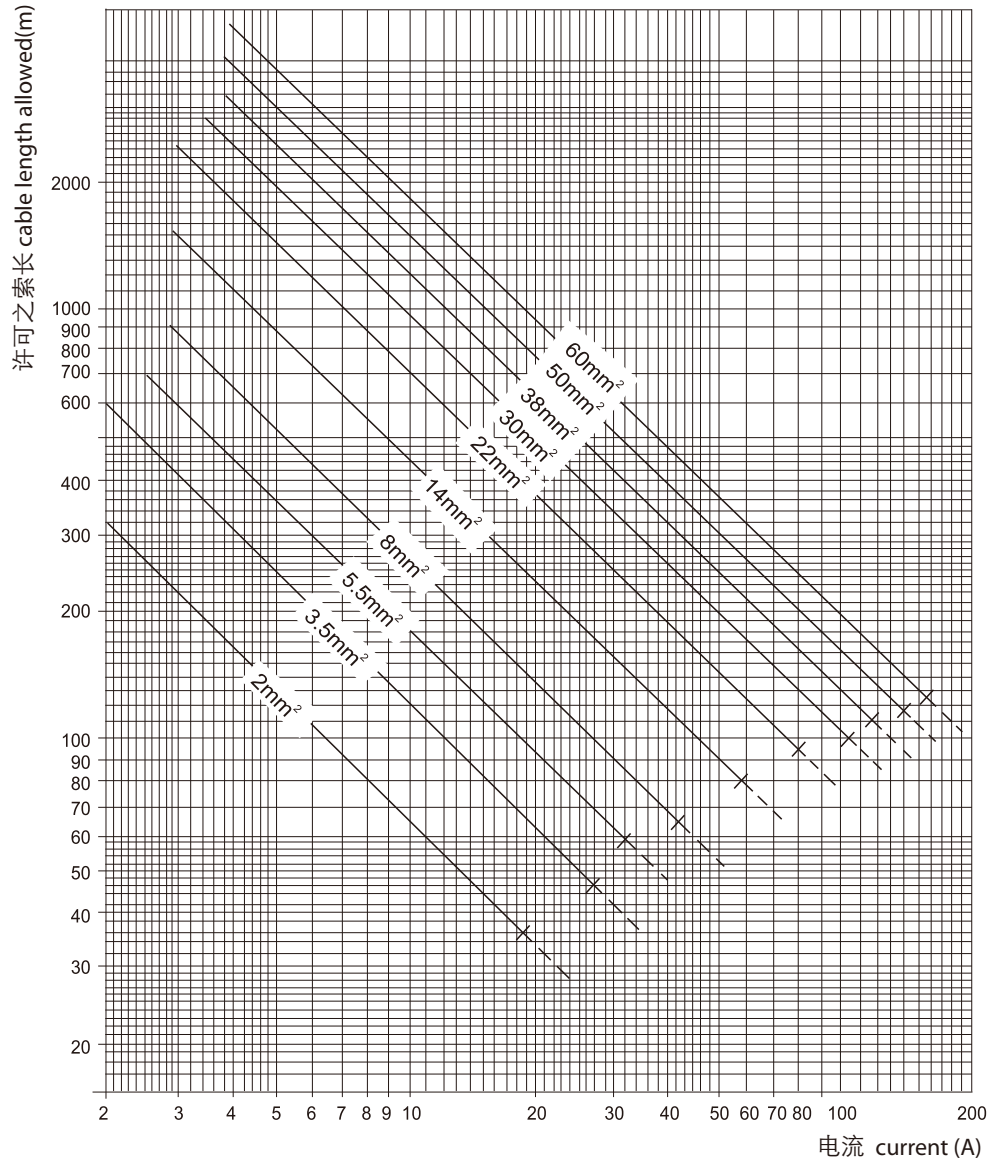

电缆应尽可能依上所示之尺寸选取用（最高环境温度30℃；在控制器与曝气机之间允许电压降为5%）。

Conductor shall be sized where applicable in accordance with the tables above. The tables are based on 30 C maximum ambient temperature with an allowable voltage drop between controller and aerator of 5%.



表面式曝气机安装注意事项

依表面式曝气机特性及水池之大小安装于适当地方。检查表面式曝气机之固定钢索是否完全绑好，浮筒是否在倾斜状态等。确认表面式曝气机之电缆是否正确被固定。一般来说，电缆应附装有挂吊环，挂吊在固定钢索上，以防止电缆因额外拉力受损。检查电压及频率是否与表面式曝气机铭牌上所示相同。

Cautions during installing the surface aerator

Install the SURFACE AERATOR in the proper position according to the characteristics of the SURFACE AERATOR and the size of the pool. Check the fixing steel wires for the SURFACE AERATOR are completely fastened and the Flotation Unit is in an inclined state. Ensure the electric cables for the SURFACE AERATOR are properly fixed. Generally, one of the electric cables is fixed with a hanging ring on the fixing steel wires according to the on-the-spot situation to prevent the wiring terminals from being damaged due to excessive pulling force of the electric cables. Check the voltage and frequency of the power supply for the acceptor are consistent to those marked on the name plate of the SURFACE AERATOR.

表面式曝气机运转注意事项

- 1、检查电源电压及频率是否与表面曝气机铭牌上所示相同。
- 2、确认控制盘之防护设备是否与表面曝气机之铭牌上所示相同。
- 3、在运转中控制盘应放在自动位置而非手动位置，以便负荷太大时自动跳开。
- 4、确认运行电流在曝气机铭牌所示电流范围以内。

Cautions during operating the surface aerator

1. Check the voltage and frequency of the power supply for the acceptor are consistent to those marked on the name plate of the SURFACE AERATOR.
2. Ensure the capacity of the protective device for the control disc is consistent to the hp(kW) marked on the name plate of the SURFACE AERATOR in order to protect the operating life of the SURFACE AERATOR.
3. During operation, the control disc should be on the "AUTO" position, not on the "MANUAL" position to avoid no leap-off due to overloads.
4. Make sure the operating electric current is within the rated current range marked on the name plate of the SURFACE AERATOR during operation.



川源（中国）机械有限公司
GSD Industrial Co., Ltd.

免费咨询电话

400-657-9066

本型录内容如有变更，恕不另行通知。

We reserve the right to change content without notice.

