



川源（中国）机械有限公司
GSD Industrial Co.,Ltd.

RSW/TRS

增压罗茨风机

RSW/TRS pressure boost roots blower



RSW/TRS 增压罗茨风机

RSW/TRS pressure boost roots blower

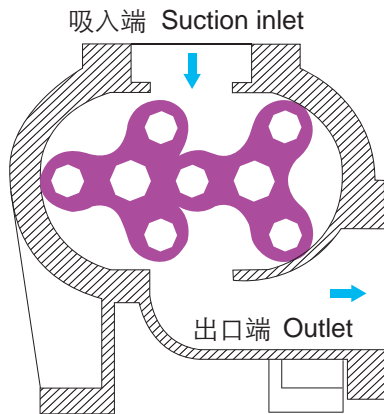

原理 Theory

RSW/TRS增压罗茨风机是一种容积式风机，其压力是可根据用户的要求在允许的范围內加以调节，在机壳内部设置有两种互相相反方向回轉的叶轮，在叶轮与叶轮，及叶轮与壳体間仅有极小縫隙的状态下回轉。当叶轮经过吸入端时，与壳体之間捕捉一定量的空气，随叶轮旋轉，空气侧移，压力逐渐升高再送至出口端。TRS增压风机是二段式鼓风机，由两台RSW风机组成。当一段RSW风机叶轮经过入口端时，与壳体之間捕捉一定量的空气，随叶轮旋轉，空气侧移，压力逐渐升高再送至出口端，完成一次增压进入冷凝器降温，再由冷凝器的另一端进入二段RSW风机，由二段风机的入口到出口完成二次增压。

RSW/TRS is a displacement blower, the pressure can be adjusted according to the requirement of the user in allowing range, there are two impellers in the blower body which rotate in the opposite direction, in order to let the impeller rotate, there are some tiny gap between the impeller to body, impeller to impeller. When the impeller rotates through the suction inlet, it can gather an amount of air between the body and impeller, then the impeller go on rotating, and the air will be pressured, the pressure in the body will rise, finally the air has been send to the outlet.

TRS is two-stage pressure boost roots blower, it combine with two sets RSW. When the impeller of the one-stage RSW blower rotates through the suction inlet, it can gather an amount of air between the body and impeller, then the impeller go on rotating, the air will be send to the outlet to finish the first pressurize, after being cooled in the condenser, the air enter the two-stage RSW blower to finish the second pressurize from the suction inlet to outlet.

特点 Features

- 风量和压力范围大。
 - 口径：50mm~300mm (2"~12")
 - 风量：RSW 2.5~171.1m³/min；TRS 1.14~166.49m³/min
 - 压力：一段式RSW型可达10000mmAq (1.0kgf/cm²)
 - 二段式TRS型可达20000mmAq (2.0kgf/cm²)
- 排出气体不含油污。
- 电脑动平衡校正，低振动低噪音。
- 风量稳定，压力变换对风机之影响小。
- 特殊叶轮设计，高效率省能源。
- 构造简单坚固，无故障。
- 使用一级研磨齿轮，精度高，寿命长，低噪音。
- 严格品质管理，标准化制品。
- 叶轮采用最新之龙门刨床六轴加工法，一次加工完成，使更换方便，其具有更高之精密度。
- 特有的水冷却设计，可以有效的降低油箱和齿轮箱內的润滑油温度，确保风机高压运行轴承和齿轮的使用寿命。
- TRS两台风机串联运行，通过二次增压，使风机实现高压力。冷凝器的冷却系统，可有效的将第一段风机排出的气体降温，到达第二段入口的温度≤40℃，确保第二段风机正常运行。
- Wide range of capacity and pressure.
 - Calibre: 50mm-300mm (2"-12")
 - Capacity: RSW 2.5~171.1m³/min; TRS 1.14~166.49m³/min
 - Pressure: The pressure of one-stage RSW type up to 10000mmAq (1.0kgf/cm²)
 - The pressure of two-stage TRS type up to 20000mmAq (2.0kg/cm²)
- Delivers completely oil-free air.
- Low oscillation and low noise by dynamic balance which revised by computer.
- Smaller change in capacity against change in pressure.
- High efficiency due to special impeller design, great air-delivery low power.
- Simpler and solidier structure, less trouble.
- Highest quality pilot & accurate great applied, long life and low noise assured.
- Standardized product with strict quality control.
- Our rotor has used the most advanced technic, one time for all working process of the six-shaft method, to enhance the precision of leave wheel.
- The special cooling design can efficiently reduce the temperature of the lubricate oil in the oil box and gear case, and then make sure the blower's gear and shaft having a long service life operating under a high pressure.
- TRS is a two-stage blowers in series, through two times pressurize, the air in the blower can get a high pressure. Through the condenser's cooling system, the air discharged from the one-stage blows outlet can be efficiently cooling down, the temperature of the air at the suction inlet of the second stage blower can be below 40℃, which can make sure the regular operation of the second stage blower.



外形结构图 Externality construction

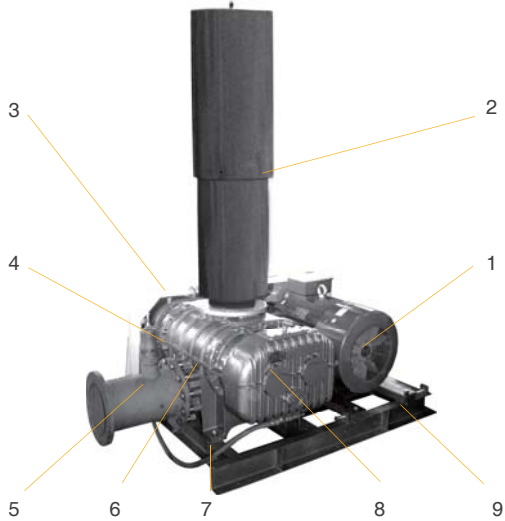

No.	名称	Name
1	电机	Motor
2	入口消音器	Inlet silencer
3	皮带护罩	Belt cover
4	泄压阀	Pressure release valve
5	三通管	T-joint
6	逆止阀	Check valve
7	冷却水管	Cooling pipe
8	风机本体	blower body
9	底座	Bottom case

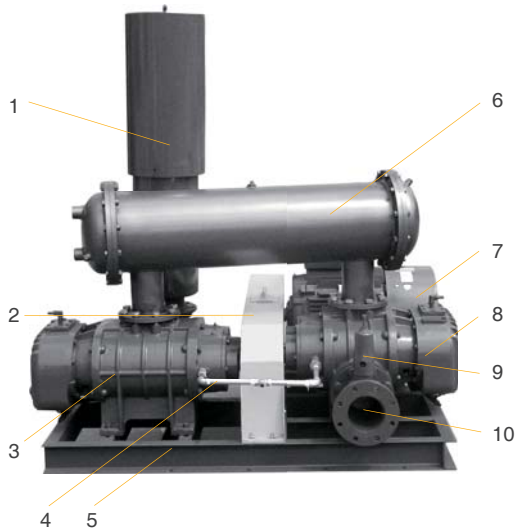

No.	名称	Name
1	入口消音器	Inlet silencer
2	皮带护罩	Belt cover
3	TRs一段风机	TRs one-stage blower
4	冷却水管	Cooling pipe
5	底座	Bottom case
6	冷凝器	Condenser
7	电机	Motor
8	TRs二段风机	TRs two-stage blower
9	泄压阀	Pressure release valve
10	三通管	T-joint

型号说明 Type description

RSW/TRS - 65

口径 (mm)

Diameter (mm)

RSW/TRS增压罗茨风机 RSW/TRS pressure boost roots blower



结构简图 Construction

No.	名称	Name	材质 Material	
			GB	JIS
1	风机机体	Casing	HT250	FC250
2	轴承座	Bearing housing	HT250	FC250
3	油箱	Oil box	HT250	FC250
4	甩油片	Oil splash	Q235	SS400
5	轴承固定片	Bearing washer	Q235	SS400
6	骨架油封	Framework oil seal	NBR	NBR
7	皮带轮	Pulley	HT250	FC250
8	主动叶轮	Drive rotor	HT250	FC250
9	被动叶轮	Driven rotor	HT250	FC250
10	V封油封	V-ring	NBR	NBR
11	轴承	Bearing	GCr15	SUJ2
12	齿轮	Gear	20CrMnTi	SCM415
13	止动垫片	Lock washer	Q235	SS400
14	圆螺母	Lock nut	45	S45C
15	齿轮箱	Gear box	HT250	FC250
16	加油柱塞	Lubrication plug	45	S45C
17	泄油柱塞	Purge plug	45	S45C
18	润滑油面计	Oil gauge	Assembly	Assembly

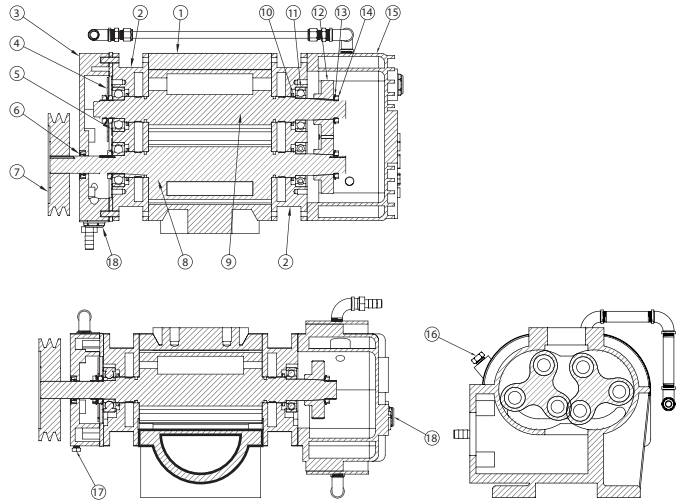

单位换算表 Conversion table

Pressure	atm	kPa	bar	lbt/in ² (psi)	kgf/cm ²	in Hg	ftAq	mmHg(Torr)	mmAq
1 atm	1	101.325	1.01325	14.696	1.0333	29.921	33.914	760	10333
1 kPa	0.0099	1	0.01	0.145	0.0102	0.295	0.335	7.5	102
1 bar	0.9869	100	1	14.504	1.0198	29.53	33.47	750	10198
1 lbt/in ² (psi)	0.068	6.894	0.0689	1	0.0703	2.036	2.308	51.71	703
1 kgf/cm ²	0.968	98.062	0.981	14.228	1	28.96	32.82	735.53	10000
1 inHg	0.0334	3.3863	0.0339	0.491	0.0345	1	1.133	25.4	345.3
1 ftAq	0.0295	2.99	0.0299	0.434	0.0305	0.882	1	22.42	304.8
1 mmHg(Torr)	0.013	0.1338	0.00138	0.019	0.0014	0.04	0.045	1	13.6
1 mmAq	0.000097	0.0098	0.000098	0.0014	0.0001	0.003	0.0033	0.074	1

Capacity	m ³ /min	l/min	cm ³ /s	in ³ /s	ft ³ /min(cfm)
1 m ³ /min	1	1000	16667	1016	35.288
1 l/min	0.001	1	16.67	1.02	0.0353
1 cm ³ /s	0.00006	0.06	1	0.061	0.02
1 in ³ /s	0.00098	0.983	16.39	1	0.035
1 ft ³ /min(cfm)	0.028	28.32	471.95	28.8	1

压力常用换算公式
 Pressure Conversion Formula
 1 kPa=1000Pa=1000N/m²
 1mbar=10.198mmAq
 1mmHg(Torr)=133.8Pa

性能参数 Performance parameters

型号 Type	转速 RPM	Qs(m³/min) Pressure(mmAq) La(kW)						冷却水量 (L/min)
		8000mmAq		9000mmAq		10000mmAq		
		Qs	La	Qs	La	Qs	La	
RSW-50	1450	2.64	5.37	2.57	5.99	2.50	6.61	4
	1550	2.90	5.74	2.83	6.40	2.76	7.06	
	1650	3.16	6.11	3.09	6.82	3.02	7.52	
	1750	3.42	6.48	3.35	7.23	3.28	7.98	
	1850	3.68	6.85	3.61	7.64	3.54	8.43	
RSW-65	1950	3.94	7.22	3.87	8.06	3.81	8.89	6
	1350	3.14	6.38	3.05	7.12	2.97	7.87	
	1450	3.48	6.85	3.39	7.65	3.31	8.46	
	1550	3.82	7.32	3.73	8.18	3.65	9.04	
RSW-80	1650	4.16	7.79	4.07	8.71	3.99	9.62	8
	1300	5.87	11.03	5.75	12.30	5.64	13.57	
	1400	6.47	11.87	6.35	13.24	6.24	14.61	
	1500	7.07	12.72	6.95	14.19	6.84	15.66	
	1600	7.67	13.57	7.55	15.14	7.44	16.70	
	1650	7.97	13.99	7.85	15.61	7.74	17.22	
	1750	8.57	14.84	8.45	16.55	8.34	18.27	
RSW-100	1850	9.16	15.69	9.05	17.50	8.94	19.31	10
	1950	9.76	16.54	9.65	18.45	9.54	20.35	
	1200	7.42	14.47	7.26	16.12	7.11	17.76	
	1300	8.26	15.68	8.10	17.46	7.95	19.24	
RSW-125A	1400	9.10	16.88	8.94	18.80	8.79	20.72	12
	1500	9.94	18.09	9.78	20.14	9.63	22.20	
	1180	11.67	20.54	11.49	22.91	11.33	25.28	
	1250	12.53	21.76	12.35	24.27	12.19	26.78	
	1320	13.39	22.97	13.22	25.63	13.05	28.28	
	1390	14.25	24.19	14.08	26.98	13.91	29.78	
	1470	15.23	25.59	15.06	28.54	14.90	31.49	
	1560	16.34	27.15	16.17	30.28	16.00	33.42	
RSW-125	1650	17.44	28.72	17.27	32.03	17.11	35.35	12
	1750	18.67	30.46	18.50	33.97	18.34	37.49	
	1850	19.90	32.20	19.73	35.91	19.57	39.63	
	1180	17.32	30.02	17.09	33.48	16.87	36.94	
	1250	18.58	31.80	18.35	35.47	18.12	39.14	
	1320	19.84	33.58	19.60	37.45	19.38	41.33	
	1390	21.10	35.36	20.86	39.44	20.64	43.52	
	1470	22.53	37.39	22.30	41.71	22.08	46.02	
RSW-150	1560	24.15	39.68	23.92	44.26	23.69	48.84	15
	1650	25.77	41.97	25.53	46.82	25.31	51.66	
	1750	27.57	44.52	27.33	49.65	27.11	54.79	
	1850	29.36	47.06	29.13	52.49	28.91	57.92	
	1180	24.09	41.00	23.79	45.73	23.51	50.46	
	1250	25.71	43.30	25.41	48.29	25.13	53.29	
	1320	27.33	45.59	27.03	50.86	26.75	56.12	
RSW-200A	1390	29.18	48.22	28.89	53.78	28.61	59.35	15
	1470	31.27	51.17	30.97	57.08	30.69	62.98	
	990	30.61	52.09	30.23	58.10	29.88	64.11	
	1050	32.84	55.25	32.46	61.62	32.11	67.99	
	1110	35.07	58.40	34.69	65.14	34.34	71.88	
	1180	37.67	62.08	37.29	69.25	36.94	76.41	
	1250	40.27	65.77	39.89	73.36	39.54	80.95	
	1320	42.87	69.45	42.50	77.46	42.14	85.48	
	1390	45.47	73.13	45.10	81.57	44.74	90.01	



性能参数 Performance parameters

型号 Type	转速 RPM	Qs(m ³ /min) Pressure(mmAq) La(kW)						冷却水量 (L/min)
		8000mmAq		9000mmAq		10000mmAq		
		Qs	La	Qs	La	Qs	La	
RSW-200	990	40.39	66.97	39.97	74.70	39.57	82.43	25
	1050	43.25	71.03	42.83	79.23	42.44	87.42	
	1110	46.12	75.09	45.70	83.75	45.30	92.42	
	1180	49.47	79.82	49.05	89.03	48.65	98.24	
	1250	52.81	84.56	52.39	94.32	51.99	104.07	
	1320	56.16	89.29	55.74	99.60	55.34	109.90	
	1390	59.50	94.03	59.08	104.88	58.68	115.73	
RSW-250	1050	58.80	94.71	58.31	105.63	57.84	116.56	25
	1110	62.62	100.12	62.13	111.67	61.66	123.22	
	1180	67.08	106.43	66.59	118.71	66.12	130.99	
	1250	71.54	112.75	71.05	125.75	70.58	138.76	
	1320	76.00	119.06	75.51	132.80	75.04	146.53	
	1390	80.46	125.37	79.97	139.84	79.50	154.30	
	1470	85.56	132.59	85.07	147.89	84.60	163.19	
RSW-300	600	64.17	113.54	63.19	139.29	62.27	161.39	30
	700	77.54	132.47	76.56	159.94	75.64	184.23	
	800	90.90	151.39	89.93	180.59	89.01	207.06	
	900	104.27	170.32	103.30	201.25	102.38	229.90	
	1000	117.64	189.24	116.67	221.90	115.75	252.73	
	1100	131.01	208.16	130.04	242.55	129.12	275.57	
	1200	144.38	227.09	143.41	263.20	142.48	298.40	
	1300	157.75	246.01	156.77	283.85	155.85	321.24	
1400	171.12	264.94	170.14	304.51	169.22	344.07		

性能参数 Performance parameters

型号 Type	转速 RPM	Qs(m³/min) Pressure(mmAq) La(kW)																								冷却水量 (L/min)
		1000mmAq		1100mmAq		1200mmAq		1300mmAq		1400mmAq		1500mmAq		1600mmAq		1700mmAq		1800mmAq		1900mmAq		2000mmAq				
		Qs	La	Qs	La	Qs	La	Qs	La	Qs	La	Qs	La	Qs	La	Qs	La	Qs	La	Qs	La	Qs	La			
TRS-50	1250	1.61	4.61	1.53	5.07	1.45	5.53	1.41	5.99	1.37	6.45	1.35	6.91	1.32	7.37	1.27	7.83	1.21	8.29	1.18	8.75	1.14	9.21	33		
	1350	1.87	4.98	1.82	5.48	1.77	5.97	1.72	6.47	1.66	6.96	1.62	7.47	1.58	7.97	1.53	8.46	1.47	8.96	1.44	9.45	1.40	9.95			
	1450	2.13	5.34	2.08	5.88	2.03	6.41	1.98	6.95	1.92	7.49	1.88	8.02	1.84	8.55	1.79	9.08	1.73	9.62	1.70	10.15	1.66	10.69			
	1550	2.39	5.71	2.34	6.28	2.29	6.85	2.24	7.43	2.18	8.00	2.14	8.57	2.10	9.14	2.05	9.71	1.99	10.28	1.95	10.85	1.92	11.42			
	1650	2.65	6.08	2.60	6.69	2.55	7.30	2.50	7.91	2.44	8.51	2.40	9.12	2.36	9.73	2.31	10.34	2.25	10.95	2.21	11.55	2.18	12.16			
	1750	2.91	6.45	2.86	7.10	2.81	7.74	2.76	8.39	2.70	9.03	2.66	9.68	2.62	10.32	2.57	10.96	2.51	11.61	2.47	12.25	2.44	12.90			
	1850	3.17	6.82	3.12	7.50	3.07	8.18	3.02	8.87	2.96	9.55	2.92	10.23	2.87	10.91	2.82	11.59	2.77	12.27	2.73	12.95	2.70	13.64			
1950	3.43	7.19	3.38	7.91	3.32	8.62	3.27	9.34	3.22	10.06	3.18	10.78	3.13	11.50	3.08	12.22	3.03	12.94	2.99	13.65	2.95	14.37				
TRS-65	1250	2.84	6.62	2.78	7.29	2.72	7.95	2.68	8.65	2.63	9.35	2.56	9.98	2.49	10.60	2.42	11.26	2.36	11.92	2.30	12.58	2.24	13.24	40		
	1350	3.18	7.15	3.12	7.87	3.06	8.58	3.02	9.29	2.97	9.99	2.90	10.72	2.82	11.45	2.76	12.16	2.69	12.87	2.64	13.59	2.58	14.30			
	1450	3.52	7.68	3.46	8.45	3.39	9.22	3.35	9.94	3.30	10.65	3.23	11.47	3.16	12.29	3.10	13.06	3.03	13.83	2.97	14.60	2.92	15.36			
	1550	3.85	8.21	3.79	9.03	3.73	9.85	3.69	10.57	3.64	11.29	3.57	12.22	3.50	13.14	3.43	13.96	3.37	14.78	3.31	15.60	3.26	16.42			
	1650	4.19	8.74	4.13	9.62	4.07	10.49	4.03	11.27	3.98	12.05	3.91	13.02	3.83	13.99	3.77	14.86	3.71	15.73	3.65	16.61	3.59	17.48			
TRS-80	1200	4.66	12.76	4.51	14.03	4.36	15.30	4.16	16.58	3.95	17.86	3.74	19.14	3.53	20.42	3.35	21.69	3.18	22.96	3.01	24.24	2.84	25.51	56		
	1300	5.26	13.82	5.11	15.20	4.96	16.58	4.76	17.96	4.55	19.34	4.34	20.73	4.13	22.12	3.95	23.50	3.78	24.88	3.61	26.26	3.44	27.64			
	1400	5.86	14.88	5.71	16.37	5.56	17.86	5.36	19.35	5.15	20.84	4.94	22.33	4.73	23.82	4.55	25.30	4.38	26.79	4.21	28.28	4.04	29.77			
	1500	6.45	15.94	6.31	17.54	6.16	19.14	5.96	20.73	5.75	22.32	5.54	23.92	5.33	25.52	5.15	27.11	4.98	28.70	4.81	30.30	4.64	31.89			
	1600	7.05	17.00	6.91	18.71	6.76	20.42	6.55	22.12	6.34	23.82	6.14	25.52	5.93	27.22	5.75	28.92	5.57	30.62	5.41	32.32	5.24	34.02			
	1650	7.35	17.54	7.21	19.29	7.06	21.04	6.85	22.80	6.64	24.56	6.44	26.31	6.23	28.06	6.05	29.82	5.87	31.57	5.70	33.33	5.54	35.08			
	1750	7.95	18.60	7.81	20.46	7.66	22.32	7.45	24.18	7.24	26.04	7.03	27.90	6.82	29.76	6.65	31.62	6.47	33.49	6.30	35.35	6.13	37.21			
1850	8.55	19.66	8.41	21.63	8.26	23.60	8.05	25.57	7.84	27.54	7.63	29.50	7.42	31.46	7.25	33.43	7.07	35.40	6.90	37.37	6.73	39.33				
1950	9.15	20.72	9.00	22.80	8.85	24.88	8.65	26.95	8.44	29.02	8.23	31.09	8.02	33.16	7.84	35.24	7.67	37.31	7.50	39.39	7.33	41.46				
TRS-100	1200	7.31	15.31	7.24	16.84	7.17	18.37	7.00	19.90	6.83	21.43	6.76	23.21	6.60	24.96	6.49	26.56	6.32	28.19	6.15	29.99	6.00	30.62	58		
	1300	8.15	16.58	8.08	18.24	8.01	19.90	7.84	21.56	7.67	23.21	7.60	24.87	7.53	26.53	7.40	28.19	7.27	29.85	7.16	31.51	7.04	33.17			
	1400	8.99	17.86	8.92	19.65	8.84	21.43	8.68	23.22	8.51	25.01	8.44	26.79	8.37	28.57	8.24	30.36	8.11	32.15	7.99	33.93	7.88	35.72			
	1500	9.82	19.13	9.75	21.05	9.68	22.96	9.52	24.88	9.35	26.79	9.28	28.70	9.21	30.62	9.08	32.53	8.95	34.44	8.83	36.36	8.72	38.27			
TRS-125	1100	14.25	29.52	13.94	32.48	13.62	35.43	13.59	38.38	13.56	41.33	13.24	44.28	12.92	47.24	12.51	50.19	12.11	53.14	11.64	56.09	11.17	59.05	74		
	1180	15.69	31.67	15.38	34.84	15.06	38.00	15.03	41.17	15.00	44.34	14.68	47.51	14.35	50.67	13.95	53.84	13.55	57.01	13.08	60.17	12.61	63.34			
	1250	16.94	33.55	16.63	36.90	16.31	40.25	16.28	43.61	16.25	46.97	15.93	50.32	15.61	53.68	15.21	57.03	14.80	60.39	14.33	63.74	13.86	67.10			
	1320	18.20	35.43	17.89	38.97	17.57	42.51	17.54	46.06	17.51	49.60	17.19	53.14	16.87	56.68	16.46	60.23	16.06	63.77	15.59	67.31	15.12	70.85			
	1390	19.46	37.31	19.15	41.04	18.83	44.77	18.80	48.50	18.77	52.23	18.45	55.96	18.12	59.69	17.72	63.42	17.32	67.15	16.85	70.88	16.38	74.61			
	1470	20.89	39.46	20.58	43.40	20.26	47.34	20.23	50.93	20.20	54.52	19.88	58.82	19.56	63.13	19.16	67.07	18.75	71.02	18.28	74.96	17.81	78.91			
	1560	22.51	41.87	22.20	46.06	21.88	50.24	21.85	54.43	21.82	58.61	21.50	62.80	21.18	66.99	20.77	71.18	20.37	75.36	19.90	79.55	19.43	83.74			
	1650	24.12	44.28	23.81	48.71	23.50	53.14	23.47	57.57	23.43	62.00	23.11	66.43	22.79	70.85	22.39	75.28	21.98	79.71	21.51	84.14	21.04	88.57			
	1750	25.92	46.97	25.61	51.67	25.29	56.36	25.26	61.06	25.23	65.75	24.91	70.45	24.59	75.15	24.18	79.85	23.78	84.54	23.31	89.24	22.84	93.94			
1850	27.71	49.65	27.40	54.62	27.09	59.59	27.06	64.55	27.02	69.51	26.70	74.48	26.38	79.44	25.98	84.41	25.57	89.37	25.10	94.34	24.64	99.30				
TRS-150	1100	18.91	40.13	18.56	44.15	18.20	48.16	17.90	52.17	17.60	56.18	17.36	60.20	17.12	64.21	16.44	64.21	15.76	64.21	15.16	72.24	14.56	80.27	87		
	1180	20.77	43.05	20.41	47.36	20.05	51.66	19.75	55.97	19.45	60.28	19.21	64.58	18.97	68.88	18.29	68.88	17.61	68.88	17.01	77.49	16.42	86.10			
	1250	22.39	45.61	22.03	50.17	21.67	54.72	21.37	59.29	21.07	63.85	20.83	68.41	20.59	72.97	19.91	72.97	19.23	72.97	18.63	82.09	18.04	91.21			
	1320	24.01	48.16	23.65	52.98	23.29	57.79	22.99	62.61	22.69	67.42	22.45	72.24	22.21	77.05	21.53	77.05	20.85	77.05	20.25	86.69	19.66	96.32			
	1390	25.63	50.71	25.27	55.78	24.91	60.85	24.61	65.93	24.31	71.00	24.07	76.07	23.83	81.14	23.15	81.14	22.47	81.14	21.87	91.28	21.28	101.43			
	1470	27.48	53.64	27.12	59.00	26.76	64.36	26.47	69.37	26.17	74.37	25.93	80.09	25.69	85.81	25.00	85.81	24.32	85.81	23.73	96.54	23.13	107.26			
TRS-200A	990	28.10	65.33	27.76	71.86	27.41	78.39	27.24	84.93	26.73	91.46	26.37	97.99	26.00	104.52	25.72	111.06	25.43	117.59	24.73	124.12	24.03	130.66	120		
	1050	30.23	69.29	29.89	76.22	29.55	83.14	29.38	90.07	28.87	97.00	28.56	103.93	28.24	110.86	27.95	117.79	27.66	124.72	26.96	131.65	26.26	138.57			
	1110	32.37	73.25	32.03	80.57	31.69	87.90	31.52	95.22	31.01	102.54	30.67	109.87	30.32	117.19	30.11	124.52	29.89	131.84	29.19	139.17	28.49	146.49			
	1180	34.90	77.87	34.51	85.65	34.12	93.44	34.02	101.23	33.53	109.01	33.18	116.80	32.83	124.58	32.66	132.37	32.49	140.16	31.79	147.94	31.09	155.73			
	1250	37.33	82.48	36.99	90.73	36.64	98.98	36.52	107.23	36.06	115.48	35.74	123.73	35.41	131.98	35.25	140.22	35.09	148.47	34.40	156.72	33.70	164.97			
	1320	39.85	87.10	39.51	95.81	39.17	104.52	39.00	113.23	38.49	121.95	38.15	130.66	37.80	139.37	37.75	148.08	37.70	156.79	37.00	165.50	36.30	174.21			
	1390	42.28	91.72	41.94	100.90	41.60	110.07	41.48	119.24	41.02	128.41	40.67	137.58	40.31	146.76	40.30	155.93	40.30	165.10	39.60	174.27	38.90	183.45			



性能参数 Performance parameters

型号 Type	转速 RPM	Qs(m ³ /min) Pressure(mmAq) La(kW)																				冷却水量 (L/min)		
		1000mmAq		1100mmAq		1200mmAq		1300mmAq		1400mmAq		1500mmAq		1600mmAq		1700mmAq		1800mmAq		1900mmAq			2000mmAq	
		Qs	La	Qs	La	Qs	La	Qs	La	Qs	La	Qs	La	Qs	La	Qs	La	Qs	La	Qs	La		Qs	La
TRS-200	990	36.10	74.66	35.65	82.13	35.20	89.59	34.80	97.06	34.40	104.52	33.70	109.95	33.01	115.38	32.83	124.89	32.65	134.39	31.75	141.85	30.84	149.32	135
	1050	38.90	79.19	38.45	87.10	38.00	95.02	37.60	102.94	37.20	110.86	36.48	116.74	35.76	122.62	35.64	132.58	35.51	142.53	34.61	150.45	33.71	158.37	
	1110	41.60	83.71	41.15	92.08	40.70	100.45	40.25	108.82	39.80	117.19	39.16	123.53	38.51	129.86	38.45	140.27	38.38	150.68	37.48	159.05	36.58	167.42	
	1180	44.80	88.99	44.35	97.89	43.90	106.79	43.50	115.69	43.10	124.58	42.41	131.11	41.72	137.63	41.73	148.91	41.73	160.18	40.83	169.08	39.92	177.98	
	1250	48.00	94.27	47.55	103.70	47.10	113.12	46.70	122.55	46.30	131.98	45.62	139.03	44.94	146.08	45.00	157.88	45.07	169.68	44.17	179.11	43.27	188.54	
	1320	51.20	99.55	50.75	109.50	50.30	119.46	49.90	129.41	49.50	139.37	48.82	146.95	48.15	154.52	48.28	166.85	48.42	179.18	47.52	189.14	46.61	199.09	
	1390	54.40	104.83	54.00	115.31	53.60	125.79	53.15	136.27	52.70	146.76	52.03	154.86	51.36	162.97	51.56	175.83	51.76	188.69	50.86	199.17	49.96	209.65	
TRS-250	990	49.60	97.99	49.15	107.79	48.70	117.59	48.20	127.39	47.70	137.19	47.18	146.99	46.67	156.79	46.14	166.59	45.60	176.39	45.05	186.18	44.50	195.98	150
	1050	53.30	103.93	52.80	114.32	52.30	124.72	51.85	135.11	51.40	145.50	50.89	155.90	50.38	166.29	49.86	176.68	49.35	187.08	48.84	197.47	48.32	207.86	
	1110	57.00	109.87	56.50	120.86	56.00	131.84	55.50	142.83	55.00	153.82	54.54	164.80	54.09	175.79	53.59	186.78	53.10	197.77	52.62	208.75	52.15	219.74	
	1180	61.30	116.80	60.80	128.48	60.30	140.16	59.80	151.84	59.30	163.52	58.86	175.20	58.41	186.88	57.94	198.56	57.47	210.24	57.04	221.92	56.61	233.60	
	1250	65.50	123.73	65.00	136.10	64.50	148.47	64.05	160.85	63.60	173.22	63.17	185.59	62.74	197.96	62.29	210.34	61.84	222.71	61.45	235.08	61.07	247.45	
	1320	69.80	130.66	69.30	143.72	68.80	156.79	68.35	169.85	67.90	182.92	67.48	195.98	67.07	209.05	66.64	222.11	66.21	235.18	65.87	248.25	65.53	261.31	
	1390	74.10	137.58	73.60	151.34	73.10	165.10	72.55	178.86	72.00	192.62	71.70	206.38	71.39	220.14	70.99	233.89	70.58	247.65	70.28	261.41	69.99	275.17	
TRS-300	700	73.90	169.83	72.90	184.60	71.90	199.37	71.05	215.98	70.20	232.60	69.42	246.38	68.65	260.17	67.47	276.43	66.30	292.69	65.13	308.95	63.97	325.21	200
	800	87.30	194.09	86.30	210.97	85.30	227.85	84.45	246.84	83.60	265.82	82.81	281.58	82.02	297.33	80.84	315.92	79.67	334.50	78.50	353.08	77.34	371.67	
	900	100.80	218.35	99.80	237.34	98.80	256.33	97.95	277.69	97.10	299.05	96.24	316.78	95.39	334.50	94.21	355.41	93.04	376.31	91.87	397.22	90.70	418.13	
	1000	114.10	242.62	113.10	263.71	112.10	284.81	111.25	308.54	110.40	332.28	109.58	351.97	108.75	371.67	107.58	394.90	106.41	418.13	105.24	441.36	104.07	464.58	
	1100	127.60	266.88	126.60	290.08	125.60	313.29	124.75	339.40	123.90	365.51	123.01	387.17	122.12	408.83	120.95	434.39	119.77	459.94	118.61	485.49	117.44	511.04	
	1200	141.00	291.14	140.00	316.46	139.00	341.77	138.15	370.25	137.30	398.73	136.40	422.37	135.49	446.00	134.32	473.88	133.14	501.75	131.98	529.63	130.81	557.50	
	1300	154.60	315.40	153.60	342.83	152.60	370.25	151.75	401.11	150.90	431.96	149.88	457.57	148.86	483.17	147.69	513.37	146.51	543.56	145.35	573.76	144.18	603.96	
	1400	166.49	339.66	165.42	369.20	164.34	398.73	163.42	431.96	162.51	465.19	162.37	492.76	162.23	520.33	161.05	552.86	159.88	585.38	158.71	617.90	157.55	650.42	



RSW外形尺寸图 RSW Installation dimensions

配用卧式出口消音器 (RSW with horizontal outlet silencer)

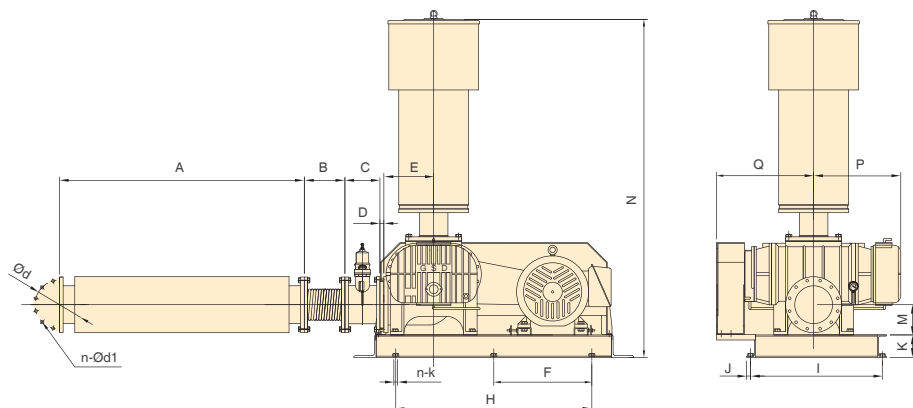

单位Unit: (mm)

型号 Type	A	B	C	D	E	F	H	I	J	K	M	N	P	Q	d	n-Ød1	n-k
RSW-50	595	180	150	18	140	-	520	412	20	80	103.5	921	314	300	125	4-Ø18	4-M12x160
RSW-65	595	208	150	18	152	-	520	412	20	80	104	924	344	323	145	4-Ø18	4-M12x160
RSW-80	795	256	180	22	180	-	700	482	20	80	106.5	1241	320	383	160	8-Ø18	4-M12x160
RSW-100	795	280	180	22	180	-	700	482	20	80	110	1245	370	426	180	8-Ø18	4-M16x220
RSW-125A	1260	330	250	22	250	-	950	602	24	100	135	1840	402	485	210	8-Ø18	4-M16x220
RSW-125	1260	330	250	22	262	-	950	602	24	100	157.5	1835	462	505	210	8-Ø18	4-M16x220
RSW-150	1260	378	250	22	250	-	950	602	24	100	163.5	1860	521.6	564	240	8-Ø23	4-M16x220
RSW-200A	1645	530	250	25	358	650	1300	790	30	160	198	2285	521	519.5	295	8-Ø23	6-M20x300
RSW-200	1645	530	250	25	345	650	1300	940	30	160	194	2520	571	565	295	8-Ø23	6-M20x300
RSW-250	1750	450	250	38	356	700	1400	940	30	160	216	2660	646	695	350	12-Ø23	6-M20x300
RSW-300	1850	510	300	38	510	1000	2000	1030	35	250	300	2955	688	840	400	12-Ø23	6-M20x300

配用立式出口消音器(RSW with vertical outlet silencer)

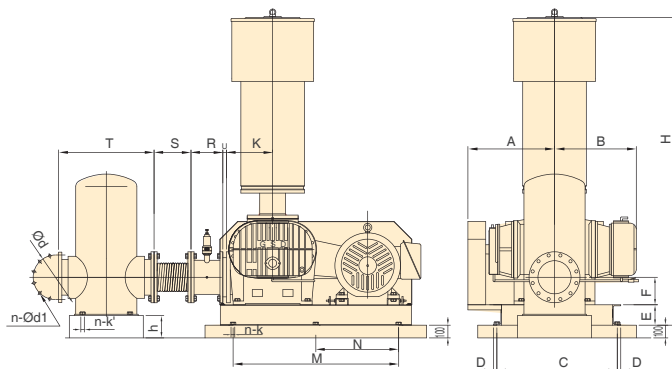

单位Unit: (mm)

型号 Type	A	B	C	D	E	F	H	M	N	K	U	R	S	T	d	n-Ød1	h	n-k	n-k
RSW-50	300	314	412	20	80	103.5	921	520	-	140	18	150	180	595	125	4-Ø18	63.5	4-M12x160	4-M12x120
RSW-65	323	344	412	20	80	104	924	520	-	152	18	150	208	595	145	4-Ø18	54	4-M12x160	4-M12x120
RSW-80	383	320	482	20	80	106.5	1241	700	-	180	22	180	256	795	160	8-Ø18	41.5	4-M12x160	4-M12x120
RSW-100	426	370	482	20	80	110	1245	700	-	180	22	180	280	795	180	8-Ø18	35	4-M16x220	4-M12x120
RSW-125A	485	402	602	24	100	135	1840	950	-	250	22	250	330	1260	210	8-Ø18	45	4-M16x220	4-M12x120
RSW-125	505	462	602	24	100	157.5	1835	950	-	262	22	250	330	1260	210	8-Ø18	67.5	4-M16x220	4-M12x120
RSW-150	564	521.6	602	24	100	163.5	1860	950	-	250	22	250	378	1260	240	8-Ø23	53.5	4-M16x220	4-M12x120
RSW-200A	519.5	521	790	30	160	198	2285	1300	650	358	25	250	530	1645	295	8-Ø23	102	6-M20x300	4-M12x120
RSW-200	565	571	940	30	160	194	2285	1300	650	345	25	250	530	1645	295	8-Ø23	98	6-M20x300	4-M12x120



TRS外形尺寸图 TRS Installation dimensions

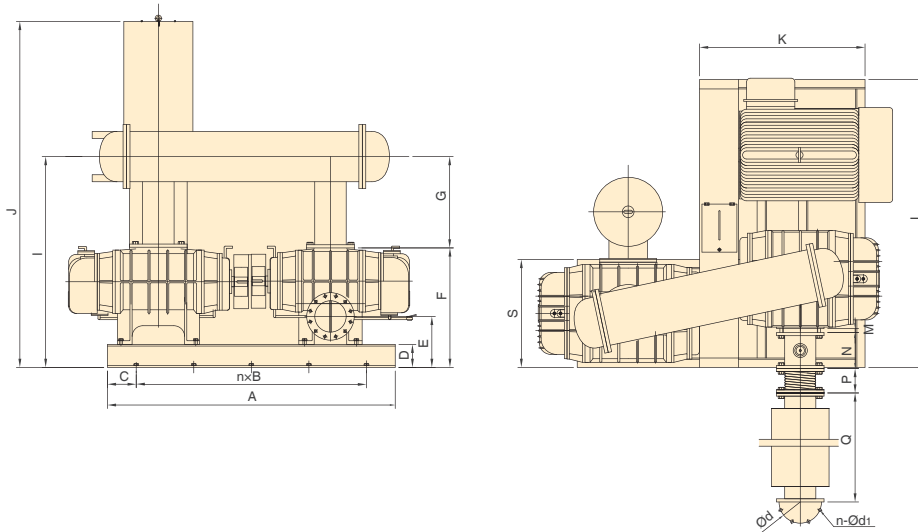

单位Unit: (mm)

型号 Type	A	nxB	C	D	E	F	G	I	J	K	L	M	N	P	Q	S	Ød	n-Ød1
TRS-50	1150	2x430	120	80	184	365	200	565	844	650	1000	18	150	160	595	320	110	4-Ø18
TRS-65	1150	2x430	120	80	184	371	240	611	889	650	1000	18	150	180	595	320	125	4-Ø18
TRS-80	1400	3x300	250	120	226	414	240	654	1214	800	1200	22	180	256	795	381	160	8-Ø18
TRS-100	1400	3x300	250	120	226	414	250	664	1214	800	1200	22	180	256	795	381	160	8-Ø18
TRS-125	1700	5x300	250	120	255	550	350	900	1790	880	1479	22	250	330	1260	560	210	8-Ø18
TRS-150	1700	5x300	250	120	255	550	425	975	1833	880	1479	22	250	330	1260	560	210	8-Ø18
TRS-200A	2000	4x400	200	160	358	785	600	1385	2173	1250	2000	25	250	530	1645	850	295	8-Ø23
TRS-200	2000	4x400	200	160	358	785	700	1485	2169	1250	2000	25	250	530	1645	850	295	8-Ø23
TRS-250	2150	4x450	175	160	354	785	555	1340	2497	1250	2000	25	250	530	1645	850	295	8-Ø23
TRS-300	2900	5x500	200	200	500	1080	600	1680	2795	1500	2850	38	300	510	1850	1206	400	12-Ø23

地脚螺栓 Anchor bolt

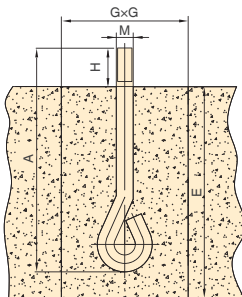

地脚螺栓 M Anchor bolt GB799-88	A	H	E	GxG	适用型号 Application type
M12	160	36	224	100x100	RSW/TRS-50,65,80,100
M16	220	45	275	120x120	RSW/TRS-125,150; RSW-125A
M20	300	55	345	150x150	RSW/TRS-200A,200,250,300A,300

注：1.图注E为最小尺寸，根据安装的土壤情况，应适当加深。

2.GxG为二次浇灌前的预留孔尺寸。

Note:1. The note E on the drawing is the minimum size, it shall be deepened properly according to the soil condition in the installation place.

2. GxG is the size of the preformed holes for the secondary casting.



入口消音器 Suction silencer

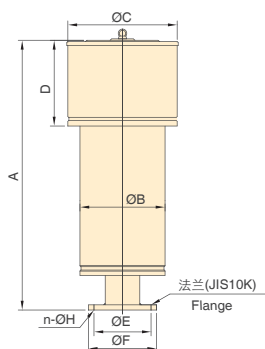

单位 Unit: (mm)

型号 Type	A	B	C	D	E	F	n-ØH	重量 Weight (kg)	适用型号 Application type
SS50	550	133	150	220	120	155	4-Ø19	10	RSW-50 TRS-50
SS65	550	159	190	280	140	175	4-Ø19	12	RSW-65 TRS-65
SS80	820	219	245	280	150	185	8-Ø19	21	RSW-80 TRS-80
SS100	820	245	273	330	175	210	8-Ø19	27	RSW-100 TRS-100
SS125	1310	273	310	350	210	250	8-Ø23	45	RSW-125(A) TRS-125
SS150	1310	299	340	370	240	280	8-Ø23	52	RSW-150 TRS-150
SS200	1500	330	380	370	290	330	12-Ø23	81	RSW-200(A) TRS-200(A)
SS250	1700	400	480	550	355	400	12-Ø25	98	RSW-250 TRS-250
SS300	1825	500	600	650	400	445	16-Ø25	135	RSW-300 TRS-300

卧式出口消音器 Horizontal outlet silencer

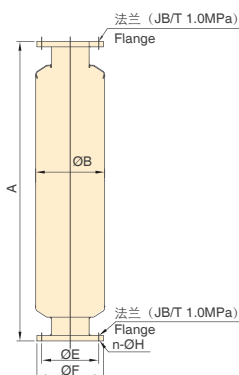

单位 Unit: (mm)

型号 Type	A	B	E	F	n-ØH	重量 Weight (kg)	适用型号 Application type
DS40	595	159	110	145	4-Ø18	11	TRS-50
DS50	595	159	125	160	4-Ø18	12	RSW-50 TRS-65
DS65	595	159	145	180	4-Ø18	13.5	RSW-65
DS80	795	219	160	195	8-Ø18	24	RSW-80 TRS-80 TRS-100
DS100	795	219	180	215	8-Ø18	25	RSW-100
DS125	1260	290	210	245	8-Ø18	48	RSW-125(A) TRS-125 TRS-150
DS150	1260	290	240	280	8-Ø23	51	RSW-150
DS200	1645	356	295	335	8-Ø23	79	RSW-200(A) TRS-200(A) TRS-250
DS250	1750	405	350	390	12-Ø23	98	RSW-250
DS300	1850	484	400	440	12-Ø23	140	RSW-300 TRS-300

立式出口消音器 Vertical outlet silencer

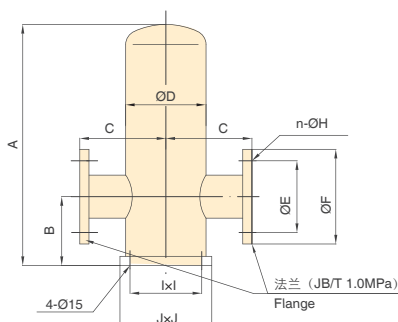

单位 Unit: (mm)

型号 Type	A	B	C	D	E	F	n-ØH	I	J	重量 Weight (kg)	适用型号 Application type
VDS50	420	120	150	140	125	160	4-Ø18	125	160	19	RSW-50
VDS65	480	130	175	191	145	180	4-Ø18	170	210	27	RSW-65
VDS80	595	145	200	216	160	195	8-Ø18	190	235	36.9	RSW-80
VDS100	660	155	225	267	180	215	8-Ø18	230	280	51.8	RSW-100
VDS125	800	190	250	280	210	245	8-Ø18	240	300	65.9	RSW-125(A)
VDS150	920	210	300	356	240	280	8-Ø23	290	376	99.6	RSW-150
VDS200	1050	256	325	406	295	335	8-Ø23	350	425	131.5	RSW-200(A)



三通管 "T" -joint

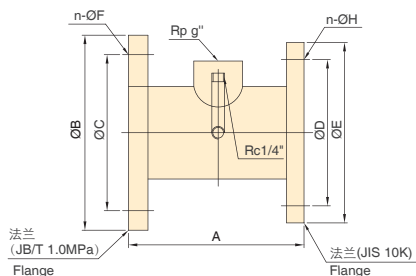

单位Unit: (mm)

型号 Type	A	B	C	n-ØH	g	E	D	n-ØH	重量 Weight (kg)	适用型号 Application type
HJ40	150	145	110	4-Ø18	1 1/4"	155	120	4-Ø19	5.5	TRS-50
HJ50	150	160	125	4-Ø18	1 1/4"	155	120	4-Ø19	5.8	RSW-50 TRS-65
HJ65	150	180	145	4-Ø18	1 1/4"	175	140	4-Ø19	7.5	RSW-65
HJ80	180	195	160	8-Ø18	1 1/4"	185	150	8-Ø19	9	RSW-80 TRS-80 TRS-100
HJ100	180	215	180	8-Ø18	2"	210	175	8-Ø19	11.5	RSW-100
HJ125	250	245	210	8-Ø18	2"	250	210	8-Ø23	15.5	RSW-125(A) TRS-125 TRS-150
HJ150	250	280	240	8-Ø23	2"	280	240	8-Ø23	18	RSW-150
HJ200	250	335	295	8-Ø23	3"	330	290	12-Ø23	23	RSW-200(A) TRS-200(A) TRS-250
HJ250	250	390	350	12-Ø23	3"	400	355	12-Ø25	30	RSW-250
HJ300	300	440	400	12-Ø23	DN100	445	400	16-Ø25	45	RSW-300 TRS-300

注: DN100为法兰连接, 参考JB/T1.0MPa规范尺寸。
Note: Type DN100 is connect with flange. Refer to JB/T 1.0MPa.

泄压阀 Relief valve

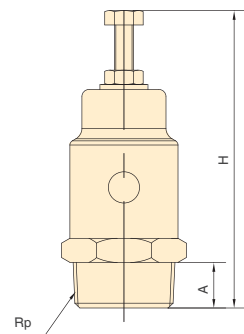

单位Unit: (mm)

型号 Type	A	H	重量 Weight (kg)	适用型号 Application type
SV1 1/4"	19	145	0.3	RSW-40、50、65、80 TRS-50、65、100
SV2"	24	185	1	RSW-100、125(A)、150 TRS-125、150
SV3"	30	230	1.6	RSW-200(A)、250 TRS-200(A)、250
SV100	90	490	29	RSW-300 TRS-300

注: SV100为法兰连接, 参考JB/T 1.0MPa法兰标准。
Note: Type SV100 is connect with flange. Refer to JB/T 1.0MPa.

逆止阀 Check valve

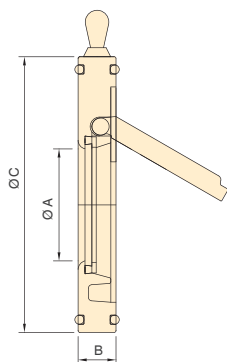

单位Unit: (mm)

型号 Type	A	B	C	重量 Weight (kg)	适用型号 Application type
DCV-50	37	18	102.5	1	RSW-50 TRS-50 TRS-65
DCV-65	45	18	122.5	1.4	RSW-65
DCV-80	52	22	132	0.8	RSW-80 TRS-80 TRS-100
DCV-100	65	22	158	0.9	RSW-100
DCV-125	90	22	190	1.2	RSW-125(A) TRS-125 TRS-150
DCV-150	115	22	215	1.5	RSW-150
DCV-200	160	25	268	2.6	RSW-200(A) TRS-200(A) TRS-250
DCV-250	180	38	325	12.5	RSW-250
DCV-300	213	38	375	18.5	RSW-300 TRS-300



TRS弯头 TRS elbow

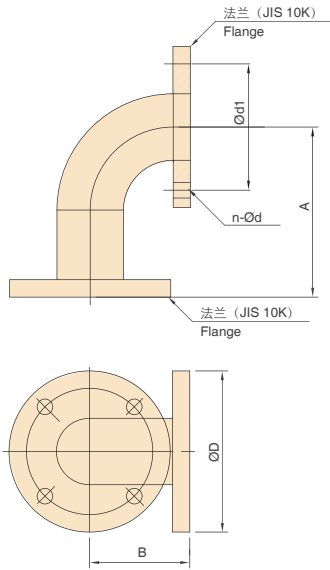

单位Unit: (mm)

适用型号 Application Type	A	B	D	d1	n-Ød
TRS-50	200	110	155	120	4-Ø19
TRS-65	200	155	175	140	4-Ø19
TRS-80	220	168	185	150	8-Ø19
TRS-100	250	164	210	175	8-Ø19
TRS-125	300	202	250	210	8-Ø23
TRS-150	320	240	280	240	8-Ø23
TRS-200(A)	315	315	330	290	12-Ø23
TRS-250	350	421	400	355	12-Ø25
TRS-300	470	470	445	400	16-Ø25

TRS冷凝器 Condenser

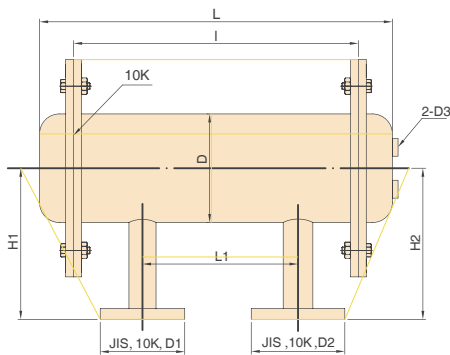

单位Unit: (mm)

型号 Type	D	D1	D2	H1	H2	L	l	L1	D3 (内螺纹)	适用型号 Application Type
25	8"	2"	1.5"	194	200	900	660	554	3/4"	TRS-50
30	8"	2.5"	2"	237	240	1000	800	594	3/4"	TRS-65
35	10"	3"	3"	193	240	1200	900	747	1"	TRS-80
40	10"	4"	3"	199	250	1300	1000	795	1"	TRS-100
50	12"	5"	5"	355	350	1400	1200	907	1"	TRS-125
60	14"	6"	5"	405	425	1500	1120	961	1"	TRS-150
80	16"	8"	8"	600	600	1600	1200	999	1"	TRS-200A
90	18"	8"	8"	700	700	1700	1250	1077	2"	TRS-200
100	20"	10"	8"	520	555	2200	1800	1229	2"	TRS-250
140	24"	12"	12"	600	600	2600	2000	1571	2"	TRS-300

波纹管 Bellows

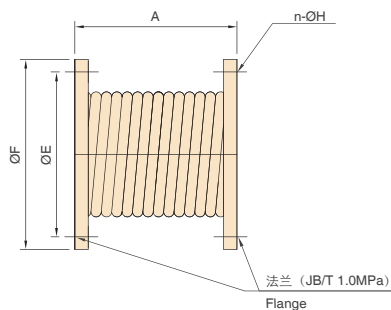

单位Unit: (mm)

型号 Type	A	E	F	n-ØH	适用型号 Application Type
WJT-40	160	Ø110	Ø150	4-Ø18	RSW-40 TRS-50
WJT-50	180	Ø125	Ø165	4-Ø18	RSW-50 TRS-65
WJT-65	208	Ø145	Ø185	4-Ø18	RSW-65
WJT-80	256	Ø160	Ø200	8-Ø18	RSW-80 TRS-80~100
WJT-100	280	Ø180	Ø220	8-Ø18	RSW-100
WJT-125	330	Ø210	Ø250	8-Ø18	RSW-125(A) TRS-125~150
WJT-150	378	Ø240	Ø285	8-Ø22	RSW-150
WJT-200	530	Ø295	Ø340	8-Ø22	RSW-200(A) TRS-200A~250
WJT-250	450	Ø350	Ø395	12-Ø22	RSW-250
WJT-300	510	Ø400	Ø455	12-Ø22	RSW/TRS-300



用途说明 Applications

水处理
Water treatment

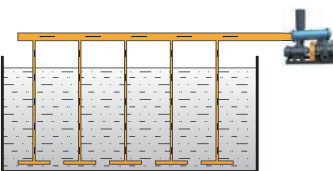

1 用于污水处理厂的曝气处理
Aeration of sewage

烟气脱硫
FGD

新鲜水
fresh water

原烟气
original flue gas

净化气
clean gas

石灰石浆
limestone slurry

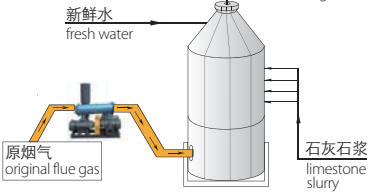

2 用于工业烟气脱硫的气体输送
For FGD's gas delivery system

物料输送
Conveying

自动下料机
automatic baiting machine

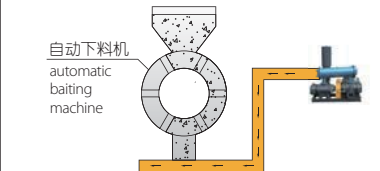

3 利用气体运动将物料输送
Use gas conveying materials

燃烧炉
Incinerator

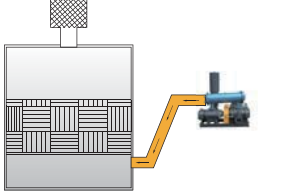

4 用于助燃，增加氧气促进燃烧
Used for combustion, increasing oxygen to promote combustion

啤酒厂、饮料行业
Brewery and beverage industry

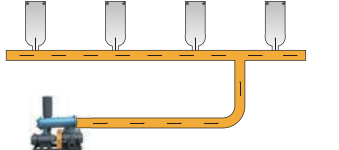

5 用于气体运动将瓶内死角清理干净
Clean up the bottle's dead angle by gas

发酵厂
Fermenting plant

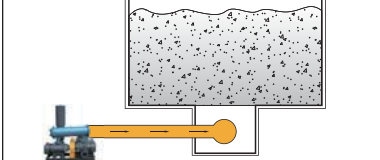

6 通过增加含氧量，来促进发酵
Increasing oxygen to promote the fermentation

喷涂
Spray finishing

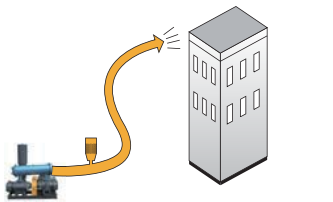

7 通过气体将防火材料喷涂到墙上或钢筋结构上
Use gas spraying fire-resistant material on the wall

洗车
Car washing

清洗剂
cleaning agent



8 洗车厂通过虹吸现象带动洗车液清洗车辆
Use washing fluid washing car base on siphon principle

电镀行业
Electroplate factory

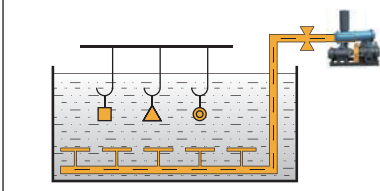

9 利用气体使液体均匀化，液体与工件充分接触
Stir gas liquid, make its uniformity

如蒙洽询请指示下列各项：
For further details, please fulfill the chart below.

客户 Customer _____ 承办人员 Undertaker _____
 工程名称 Name of project _____ 工程地点 Address of project _____
 电话 Telephone _____ 传真 Fax _____

* 当地状况 Local condition	海拔m Elevation		最高相对湿度% Max relative humidity	
	当地大气压力(MPa) Local atmospheric pressure		最高气温(°C) Max air temperature	
* 气体性质 Gas character	名称 Name		温度(°C) Temperature	
	成份 Constituents		各组分比例 Ratio of constituent	
风机参数 Blower's parameter	* 风量(m ³ /min) Capacity		口径(mm) Diameter	
	* 风压(mmAq) Pressure		转速(r/min) Speed	
电机参数 Motor's parameter	型式 Type		电压(V) Voltage	
	功率(kW) Power		频率(Hz) Frequency	
	极数 Pole		其它 Others	
安装位置 Location	<input type="checkbox"/> 室内安装 Indoor install	<input type="checkbox"/> 遮雨棚式室外安装 Camping outdoor install	<input type="checkbox"/> 其它 Others_____	
* 传动方式 Driving mode	<input type="checkbox"/> 皮带传动(标准型) Belt-driven(Standard)		<input type="checkbox"/> 直联传动 Direct drive	
其它要求 Other requirement				

备注：1.以上资料请尽可能完整填写。

2.项目前加注“*”者，请务必填写。

Notes: 1. Please fill in the parameter lists as complete as possible.

2. The item with "*" must be filled.



欢迎索取以下产品型录



泵系列

- 潜水泵系列
- 陆上泵系列
- 特种泵系列
- 消防泵系列



搅拌推流系列

- 搅拌机系列
- 推流器系列



供氧曝气系列

- 曝气机系列
- 曝气盘系列
- 曝气管系列



风机系列

- 三叶罗茨鼓风机系列
- 增压罗茨鼓风机系列
- 沉水式风机系列



污泥处理设备 及其他

- 固液分离系列
- 泡药设备
- 输送设备



川源（中国）机械有限公司
GSD Industrial Co.,Ltd.

免费咨询电话

400-657-9066

本型录内容如有变更，恕不另行通知。
We reserve the right to change content without notice.

CY-G7

