



川源（中国）机械有限公司
GSD Industrial Co.,Ltd.



HRB

高效率三叶罗茨鼓风机

HRB high efficiency three-lobe roots blower

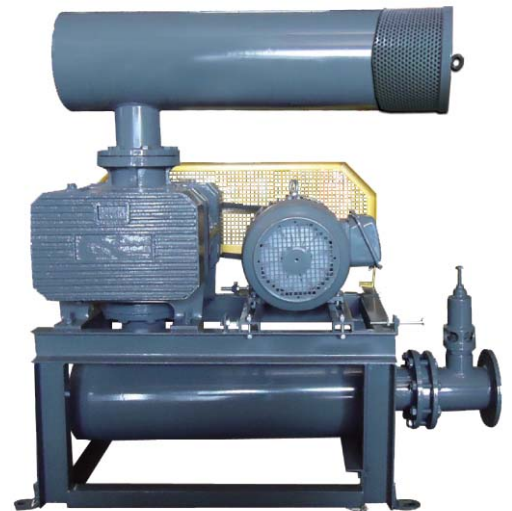

HRB 高效率三叶罗茨鼓风机

HRB high efficiency three-lobe roots blower

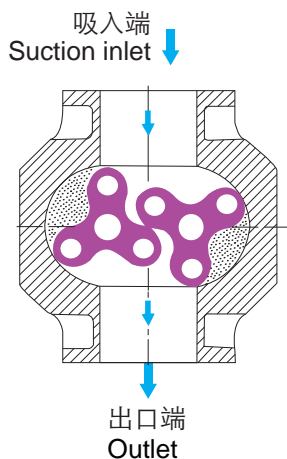

原理 Theory

HRB三叶罗茨风机是一种容积式风机，其压力可根据用户要求在允许的范围内加以调节，在机壳内部设置有两组互相相反方向回转的叶轮，可在叶轮与叶轮、叶轮与壳体间仅留微小缝隙的状态下回转。当叶轮经过吸入端时，与壳体之间捕捉一定量的空气，随叶轮转旋，空气移动，压力逐渐升高再送至出口端。

HRB is a displacement blower, the pressure can be adjusted according to the requirement of the user in allowing range. There are two impellers in the blower body which rotate in the opposite direction, in order to let the impeller rotate, there are some tiny gaps between the impeller and body, impeller and impeller. When the impeller rotates through the suction inlet, it can gather an amount of air between the body and impeller, then the impeller go on rotating, and the air will be pressured, the pressure in the body will rise, finally the air has been sent to the outlet.

特点 Features

HRB系列三叶罗茨鼓风机是在GRB系列风机基础上，进行了一系列研究发展起来的。该风机最大的特点是高转速（最高可达4000RPM），高容量。通过技术的突破和不断在实践中优化，HRB系列具有更高的效率、更高的压力和较轻的重量。进气口尺寸从2.5"至12"。单台风机的压力可达到1kgf/cm²。

- 高效率
优秀的线性设计，减少转子截面积，以提高鼓风机的效率。
- 低振动
高平衡精度（G2.5）级可以控制的X，Y，Z轴振动坐标。
- 低损耗压力
180度的入口和出口之间的垂直结构，减少压力损失。

HRB series 3-lobe roots blowers are researched and developed on a basis of GRB series. The biggest feature of this blower is high rotation speed (the maximum can be 4000 RPM), high capacity. With the break-through of technology and the modification of practical application, HRB series blowers have higher efficiency, higher pressure and lower weight. The inlet sizes are from 2.5" to 12". The pressure of single blower can be 1 kgf/cm².

- High efficiency
Great liner structure, reduce sectional area of rotors to improve capacity of blowers.
- Low vibration
High grade of balance accuracy (G2.5) can control the vibration of X, Y, Z coordinate.
- Low loss of pressure
180 degrees vertical structure between inlet and outlet, reduce its pressure loss of blowers.

外形结构图 Externality construction

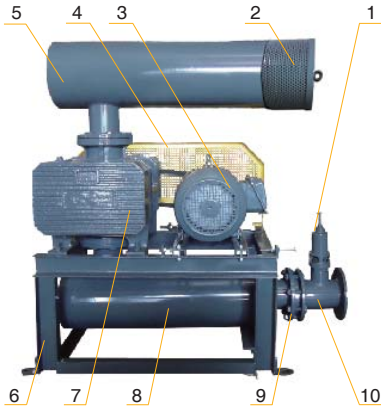

NO.	名称	NAME
1	泄压阀	Relief valve
2	过滤器	Filter barrel
3	电机	Motor
4	防雨罩	Hood
5	入口消音器	Inlet silencer
6	底座	Bottom case
7	本体	Main body
8	出口消音器	Outlet silencer
9	逆止阀	Check valve
10	三通管	T-joint

型号说明 Type description

HRB - 65

口径(mm)

Diameter(mm)

高效率三叶罗茨风机

High efficiency three-lobe roots blower

结构简图 Construction

NO.	名称	Name	材质 Material	
			GB	JIS
1	油箱	Oil box	HT250	FC250
2	风机脚	Foot	Q235	SS400
3	轴承座	Bearing housing	HT250	FC250
4	机体	Casing	HT250	FC250
5	齿轮箱	Gear box	HT250	FC250
6	加油螺栓	lubrication plug	45	S45C
7	润滑油面计	Oil gauge	组合件	组合件
8	泄油螺栓	Purge plug	45	S45C
9	被动叶轮	Driven rotor	组合件	组合件
10	主动叶轮	Drive rotor	组合件	组合件
11	甩油片	Oil splash	Q235	SS400
12	轴承固定片	Bearing washer	Q235	SS400
13	活塞环	Piston ring	HT200	FC200
14	骨架油封	Framework oil seal	NBR	NBR
15	轴承	Bearing	GCr15	SUJ2
16	齿轮	Gear	20GrMnTi	-
17	止动垫圈	Lock washer	Q235	SS400
18	止动螺母	Lock nut	45	S45C

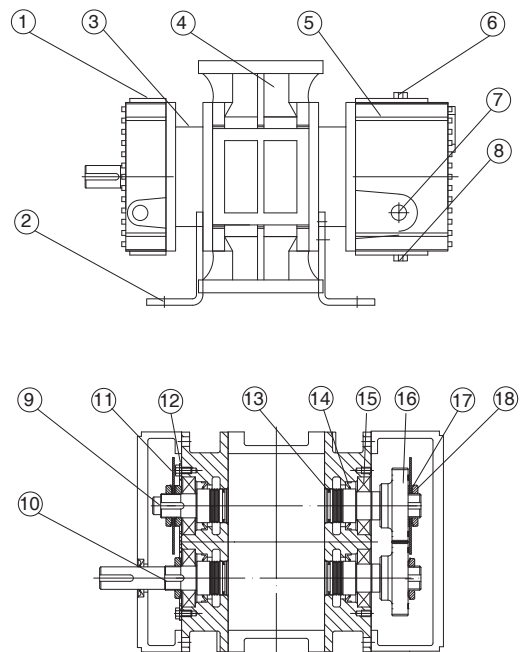

单位换算表 Conversion table

PRESSURE	atm	kPa	bar	lbt/in ² (psi)	kgf/cm ²	in Hg	ftAq	mmHg(Torr)	mmAq
1 atm	1	101.325	1.01325	14.696	1.0333	29.921	33.914	760	10333
1 kPa	0.0099	1	0.01	0.145	0.0102	0.295	0.335	7.5	102
1 bar	0.9869	100	1	14.504	1.0198	29.53	33.47	750	10198
1 lbt/in ² (psi)	0.068	6.894	0.0689	1	0.0703	2.036	2.308	51.71	703
1 kgf/cm ²	0.968	98.062	0.981	14.228	1	28.96	32.82	735.53	10000
1 inHg	0.0334	3.3863	0.0339	0.491	0.0345	1	1.133	25.4	345.3
1 ftAq	0.0295	2.99	0.0299	0.434	0.0305	0.882	1	22.42	304.8
1 mmHg(Torr)	0.013	0.1338	0.00138	0.019	0.0014	0.04	0.045	1	13.6
1 mmAq	0.000097	0.0098	0.000098	0.0014	0.0001	0.003	0.0033	0.074	1

CAPACITY	m ³ /min	l/min	cm ³ /s	in ³ /s	ft ³ /min(cfm)
1 m ³ /min	1	1000	16667	1016	35.288
1 l/min	0.001	1	16.67	1.02	0.0353
1 cm ³ /s	0.00006	0.06	1	0.061	0.002
1 in ³ /s	0.00098	0.983	16.39	1	0.035
1 ft ³ /min(cfm)	0.028	28.32	471.95	28.8	1

压力常用换算公式

Pressure Conversion Formula

1 kPa=1000Pa=1000N/m²

1mbar=10.198mmAq

1mmHg(Torr)=133.8Pa

性能表使用须知 Working directions of performance table

- 性能参数表示鼓风机之型式、口径、回转数、吐出压力、实际进口风量、轴动力。
- 性能参数为标准吸入状态之空气量(温度20℃, 绝对压力1.0332kgf/cm², 相对湿度65%)。
- 基准状态(温度0℃, 绝对压力1.0332kgf/cm²)的风量, 一般以Nm³/min表示。
- 不同状态进口风量的换算:

$$Q_2 = Q_1 \times \frac{P_1}{P_2} \times \frac{273+T_2}{273+T_1}$$

Q₁: 绝对压力P₁(mmAq) 摄氏温度T₁(℃)状态的
风量(m³/min)

Q₂: 绝对压力P₂(mmAq) 摄氏温度T₂(℃)状态的
风量(m³/min)
- 电机功率一般为轴功率的1.1~1.3倍。
- 性能参数误差约5%。

- The performance parameter indicate the type, caliber, revolutions, discharge pressure, actual inlet air capacity and shaft power of the blower.
- The performance parameter indicate the air quantity in standard suction condition (temperature 20℃, absolute pressure 1.0332 kgf/cm² and relative humidity 65%) .
- The reference air capacity (temperature 0℃ and absolute pressure 1.0332kgf/cm²) is generally indicated in Nm³/min.
- The inlet air capacity can be converted as following.

$$Q_2 = Q_1 \times \frac{P_1}{P_2} \times \frac{273+T_2}{273+T_1}$$

Q₁: Air capacity (m³/min) based on absolute pressure P₁(mmAq) and temperature T₁(℃)

Q₂: Air capacity (m³/min) based on absolute pressure P₂(mmAq) and temperature T₂(℃)
- The motor power is 1.1~1.3 multiple of shaft power.
- The error of the parameter is about 5%.



性能参数 Performance parameters

Qs(m³/min) Pressure(mmAq) La (kW)

型号 Type	转速 RPM	1000mmAq		2000mmAq		3000mmAq		4000mmAq		5000mmAq		6000mmAq		7000mmAq		8000mmAq		9000mmAq		10000mmAq	
		Qs	La	Qs	La	Qs	La	Qs	La	Qs	La	Qs	La	Qs	La	Qs	La	Qs	La	Qs	La
		HRB-65	1950	2.74	0.96	2.61	1.46	2.51	1.96	2.43	2.46	2.36	2.96	2.29	3.46	2.23	3.96	2.17	4.46	2.12	4.96
	2050	2.90	1.01	2.77	1.54	2.67	2.06	2.59	2.58	2.51	3.11	2.45	3.63	2.38	4.16	2.33	4.68	2.27	5.21	2.22	5.73
	2150	3.06	1.06	2.93	1.61	2.83	2.16	2.74	2.71	2.67	3.26	2.60	3.81	2.54	4.36	2.48	4.91	2.43	5.46	2.38	6.01
	2250	3.21	1.11	3.08	1.69	2.98	2.26	2.90	2.84	2.83	3.41	2.76	3.99	2.70	4.57	2.64	5.14	2.59	5.72	2.54	6.29
	2350	3.37	1.16	3.24	1.76	3.14	2.36	3.06	2.96	2.98	3.56	2.92	4.17	2.85	4.77	2.80	5.37	2.74	5.97	2.69	6.57
	2450	3.53	1.21	3.40	1.83	3.30	2.46	3.21	3.09	3.14	3.72	3.07	4.34	3.01	4.97	2.95	5.60	2.90	6.23	2.85	6.85
	2550	3.68	1.26	3.55	1.91	3.45	2.56	3.37	3.22	3.30	3.87	3.23	4.52	3.17	5.17	3.11	5.83	3.06	6.48	3.01	7.13
	2650	3.84	1.31	3.71	1.98	3.61	2.66	3.53	3.34	3.45	4.02	3.39	4.70	3.32	5.38	3.27	6.06	3.21	6.73	3.16	7.41
	2750	4.00	1.36	3.87	2.06	3.77	2.76	3.68	3.47	3.61	4.17	3.54	4.88	3.48	5.58	3.42	6.28	3.37	6.99	3.32	7.69
	2850	4.15	1.40	4.02	2.13	3.92	2.86	3.84	3.59	3.77	4.32	3.70	5.05	3.64	5.78	3.58	6.51	3.53	7.24	3.48	7.97
	2950	4.31	1.45	4.18	2.21	4.08	2.96	4.00	3.72	3.92	4.48	3.86	5.23	3.79	5.99	3.74	6.74	3.68	7.50	3.63	8.25
	3050	4.47	1.50	4.34	2.28	4.24	3.07	4.15	3.85	4.08	4.63	4.01	5.41	3.95	6.19	3.89	6.97	3.84	7.75	3.79	8.53
	3150	4.62	1.55	4.49	2.36	4.39	3.17	4.31	3.97	4.24	4.78	4.17	5.59	4.11	6.39	4.05	7.20	4.00	8.00	3.95	8.81
	3250	4.78	1.60	4.65	2.43	4.55	3.27	4.47	4.10	4.39	4.93	4.33	5.76	4.27	6.59	4.21	7.43	4.15	8.26	4.10	9.09
	3350	4.94	1.65	4.81	2.51	4.71	3.37	4.62	4.22	4.55	5.08	4.48	5.94	4.42	6.80	4.36	7.66	4.31	8.51	4.26	9.37
	3450	5.09	1.70	4.96	2.58	4.86	3.47	4.78	4.35	4.71	5.23	4.64	6.12	4.58	7.00	4.52	7.88	4.47	8.77	4.42	9.65
HRB-80	1950	4.69	1.40	4.52	2.23	4.39	3.06	4.28	3.89	4.18	4.73	4.10	5.56	4.02	6.39	3.94	7.22	3.87	8.06	3.81	8.89
	2050	4.95	1.47	4.78	2.35	4.65	3.22	4.54	4.09	4.44	4.97	4.36	5.84	4.28	6.72	4.20	7.59	4.13	8.47	4.07	9.34
	2150	5.21	1.54	5.04	2.46	4.91	3.38	4.80	4.29	4.71	5.21	4.62	6.13	4.54	7.05	4.46	7.96	4.39	8.88	4.33	9.80
	2250	5.47	1.61	5.30	2.57	5.17	3.53	5.06	4.49	4.97	5.45	4.88	6.41	4.80	7.37	4.73	8.33	4.66	9.29	4.59	10.25
	2350	5.73	1.69	5.56	2.69	5.43	3.69	5.32	4.69	5.23	5.70	5.14	6.70	5.06	7.70	4.99	8.70	4.92	9.71	4.85	10.71
	2450	5.99	1.76	5.82	2.80	5.70	3.85	5.59	4.89	5.49	5.94	5.40	6.98	5.32	8.03	5.25	9.08	5.18	10.12	5.11	11.17
	2550	6.25	1.83	6.09	2.92	5.96	4.01	5.85	5.09	5.75	6.18	5.66	7.27	5.58	8.36	5.51	9.45	5.44	10.53	5.37	11.62
	2650	6.52	1.90	6.35	3.03	6.22	4.16	6.11	5.29	6.01	6.42	5.93	7.55	5.85	8.69	5.77	9.82	5.70	10.95	5.64	12.08
	2750	6.78	1.97	6.61	3.15	6.48	4.32	6.37	5.49	6.27	6.67	6.19	7.84	6.11	9.01	6.03	10.19	5.96	11.36	5.90	12.53
	2850	7.04	2.04	6.87	3.26	6.74	4.48	6.63	5.69	6.53	6.91	6.45	8.12	6.37	9.34	6.29	10.56	6.22	11.77	6.16	12.99
	2950	7.30	2.12	7.13	3.37	7.00	4.63	6.89	5.89	6.80	7.15	6.71	8.41	6.63	9.67	6.55	10.93	6.48	12.19	6.42	13.45
	3050	7.56	2.19	7.39	3.49	7.26	4.79	7.15	6.09	7.06	7.39	6.97	8.69	6.89	10.00	6.82	11.30	6.75	12.60	6.68	13.90
HRB-80	3150	7.82	2.26	7.65	3.60	7.52	4.95	7.41	6.29	7.32	7.64	7.23	8.98	7.15	10.32	7.08	11.67	7.01	13.01	6.94	14.36
	3250	8.08	2.33	7.91	3.72	7.79	5.10	7.68	6.49	7.58	7.88	7.49	9.27	7.41	10.65	7.34	12.04	7.27	13.43	7.20	14.81
	3350	8.34	2.40	8.18	3.83	8.05	5.26	7.94	6.69	7.84	8.12	7.75	9.55	7.67	10.98	7.60	12.41	7.53	13.84	7.46	15.27
	3450	8.61	2.47	8.44	3.95	8.31	5.42	8.20	6.89	8.10	8.36	8.02	9.84	7.94	11.31	7.86	12.78	7.79	14.25	7.73	15.72
	3550	8.87	2.55	8.70	4.06	8.57	5.58	8.46	7.09	8.36	8.61	8.28	10.12	8.20	11.64	8.12	13.15	8.05	14.66	7.99	16.18
	3650	9.13	2.62	8.96	4.18	8.83	5.73	8.72	7.29	8.62	8.85	8.54	10.41	8.46	11.96	8.38	13.52	8.31	15.08	8.25	16.64
	3750	9.39	2.69	9.22	4.29	9.09	5.89	8.98	7.49	8.89	9.09	8.80	10.69	8.72	12.29	8.64	13.89	8.57	15.49	8.51	17.09
	3850	9.65	2.76	9.48	4.40	9.35	6.05	9.24	7.69	9.15	9.33	9.06	10.98	8.98	12.62	8.91	14.26	8.84	15.90	8.77	17.55
	3950	9.91	2.83	9.74	4.52	9.61	6.20	9.50	7.89	9.41	9.58	9.32	11.26	9.24	12.95	9.17	14.63	9.10	16.32	9.03	18.00
	4050	10.17	2.90	10.00	4.63	9.88	6.36	9.77	8.09	9.67	9.82	9.58	11.55	9.50	13.27	9.43	15.00	9.36	16.73	9.29	18.46
	4150	10.43	2.98	10.27	4.75	10.14	6.52	10.03	8.29	9.93	10.06	9.84	11.83	9.76	13.60	9.69	15.37	9.62	17.14	9.55	18.91
	4250	10.70	3.05	10.53	4.86	10.40	6.68	10.29	8.49	10.19	10.30	10.11	12.12	10.03	13.93	9.95	15.74	9.88	17.56	9.82	19.37
	4350	10.96	3.12	10.79	4.98	10.66	6.83	10.55	8.69	10.45	10.54	10.37	12.40	10.29	14.26	10.21	16.11	10.14	17.97	10.08	19.83
HRB-100	2050	9.22	2.67	8.97	4.28	8.78	5.88	8.62	7.49	8.48	9.09	8.35	10.70	8.23	12.30	8.12	13.91	8.02	15.51	7.92	17.12
	2150	9.70	2.81	9.45	4.49	9.26	6.17	9.10	7.85	8.96	9.54	8.83	11.22	8.71	12.90	8.60	14.59	8.50	16.27	8.40	17.95
	2250	10.18	2.94	9.93	4.70	9.74	6.46	9.58	8.22	9.44	9.98	9.31	11.74	9.19	13.50	9.08	15.27	8.98	17.03	8.88	18.79
	2350	10.66	3.07	10.41	4.91	10.22	6.75	10.06	8.59	9.92	10.43	9.79	12.27	9.67	14.10	9.56	15.94	9.46	17.78	9.36	19.62
	2450	11.14	3.20	10.89	5.11	10.70	7.03	10.54	8.95	10.40	10.87	10.27	12.79	10.15	14.71	10.04	16.62	9.94	18.54	9.84	20.46
	2550	11.62	3.33	11.37	5.32	11.18	7.32	11.02	9.32	10.88	11.31	10.75	13.31	10.63	15.31	10.52	17.30	10.42	19.30	10.32	21.29
	2650	12.10	3.46	11.85	5.53	11.66	7.61	11.50	9.68	11.35	11.76	11.23	13.83	11.11	15.91	11.00	17.98	10.89	20.05	10.80	22.13
	2750	12.58	3.59	12.33	5.74	12.14	7.89	11.98	10.05	11.83	12.20	11.71	14.35	11.59	16.51	11.48	18.66	11.37	20.81	11.28	22.96
	2850	13.06	3.72	12.81	5.95	12.62	8.18	12.46	10.41	12.31	12.64	12.19	14.87	12.07	17.11	11.96	19.34	11.85	21.57	11.76	23.80
	2950	13.54	3.85	13.29	6.16	13.10	8.47	12.94	10.78	12.79	13.09	12.66	15.40	12.55	17.71	12.44	20.02	12.33	22.33	12.24	24.63



性能参数 Performance parameters

Qs(m³/min) Pressure(mmAq) La (kW)

型号 Type	转速 RPM	1000mmAq		2000mmAq		3000mmAq		4000mmAq		5000mmAq		6000mmAq		7000mmAq		8000mmAq		9000mmAq		10000mmAq	
		Qs	La	Qs	La	Qs	La	Qs	La	Qs	La	Qs	La	Qs	La	Qs	La	Qs	La	Qs	La
HRB-200	2350	55.04	15.52	54.23	24.82	53.60	34.13	53.08	43.44	52.62	52.75	52.20	62.06	51.82	71.37	51.46	80.68	51.12	89.99	50.80	99.30
	2450	57.46	16.18	56.65	25.88	56.03	35.59	55.50	45.29	55.04	55.00	54.62	64.70	54.24	74.41	53.88	84.11	53.55	93.82	53.23	103.52
	2550	59.89	16.84	59.08	26.94	58.45	37.04	57.93	47.14	57.47	57.24	57.05	67.34	56.67	77.44	56.31	87.54	55.97	97.65	55.65	107.75
	2650	62.31	17.50	61.50	27.99	60.88	38.49	60.36	48.99	59.89	59.49	59.48	69.98	59.09	80.48	58.73	90.98	58.40	101.47	58.08	111.97
HRB-250	1320	60.63	17.17	59.62	27.48	58.84	37.78	58.18	48.08	57.61	58.38	57.08	68.69	56.60	78.99	56.16	89.29	55.74	99.60	55.34	109.90
	1390	63.98	18.08	62.96	28.93	62.19	39.78	61.53	50.63	60.95	61.48	60.43	72.33	59.95	83.18	59.50	94.03	59.08	104.88	58.68	115.73
	1480	68.28	19.25	67.26	30.81	66.49	42.36	65.83	53.91	65.25	65.46	64.73	77.01	64.25	88.57	63.80	100.12	63.38	111.67	62.99	123.22
	1560	72.10	20.29	71.09	32.47	70.31	44.65	69.65	56.82	69.08	69.00	68.55	81.18	68.07	93.35	67.63	105.53	67.21	117.71	66.81	129.88
	1650	76.40	21.46	75.39	34.34	74.61	47.22	73.95	60.10	73.38	72.98	72.85	85.86	72.37	98.74	71.93	111.62	71.51	124.50	71.11	137.38
	1750	81.18	22.77	80.17	36.43	79.39	50.08	78.73	63.74	78.16	77.40	77.63	91.06	77.15	104.72	76.71	118.38	76.29	132.04	75.89	145.70
	1850	85.96	24.07	84.95	38.51	84.17	52.95	83.51	67.39	82.93	81.83	82.41	96.27	81.93	110.71	81.48	125.15	81.06	139.59	80.67	154.03
	1950	90.74	25.37	89.73	40.59	88.95	55.81	88.29	71.03	87.71	86.25	87.19	101.47	86.71	116.69	86.26	131.91	85.84	147.13	85.45	162.35
	2050	95.52	26.67	94.50	42.67	93.73	58.67	93.07	74.67	92.49	90.67	91.97	106.67	91.49	122.68	91.04	138.68	90.62	154.68	90.23	170.68
	2150	100.30	27.97	99.28	44.75	98.51	61.53	97.85	78.31	97.27	95.10	96.75	111.88	96.27	128.66	95.82	145.44	95.40	162.22	95.00	179.00
HRB-300	1050	91.19	25.88	89.58	41.40	88.35	56.93	87.31	72.46	86.40	87.98	85.57	103.51	84.81	119.04	84.10	134.56	83.44	150.09	82.81	165.62
	1110	96.62	27.36	95.01	43.77	93.78	60.18	92.74	76.60	91.83	93.01	91.00	109.42	90.24	125.84	89.53	142.25	88.87	158.67	88.24	175.08
	1180	102.95	29.08	101.35	46.53	100.12	63.98	99.08	81.43	98.17	98.88	97.34	116.32	96.58	133.77	95.87	151.22	95.21	168.67	94.58	186.12
	1250	109.29	30.81	107.69	49.29	106.46	67.77	105.42	86.26	104.50	104.74	103.68	123.23	102.92	141.71	102.21	160.19	101.54	178.68	100.92	197.16
	1320	115.63	32.53	114.02	52.05	112.79	71.57	111.76	91.09	110.84	110.61	110.01	130.13	109.25	149.65	108.55	169.16	107.88	188.68	107.25	208.20
	1390	121.97	34.26	120.36	54.81	119.13	75.36	118.09	95.92	117.18	116.47	116.35	137.03	115.59	157.58	114.88	178.13	114.22	198.69	113.59	219.24
	1480	130.11	36.47	128.51	58.36	127.28	80.24	126.24	102.13	125.33	124.01	124.50	145.90	123.74	167.78	123.03	189.67	122.37	211.55	121.74	233.44
	1560	137.36	38.45	135.75	61.51	134.52	84.58	133.48	107.65	132.57	130.72	131.74	153.79	130.98	176.85	130.27	199.92	129.61	222.99	128.98	246.06
	1650	145.51	40.66	143.90	65.06	142.67	89.46	141.63	113.86	140.72	138.26	139.89	162.66	139.13	187.06	138.42	211.46	137.76	235.85	137.13	260.25
	1750	154.56	43.13	152.95	69.01	151.72	94.88	150.68	120.76	149.77	146.64	148.94	172.52	148.18	198.39	147.48	224.27	146.81	250.15	146.18	276.03
1850	163.61	45.59	162.01	72.95	160.78	100.31	159.74	127.66	158.82	155.02	158.00	182.37	157.24	209.73	156.53	237.09	155.86	264.44	155.24	291.80	



外形尺寸图 Installation dimensions

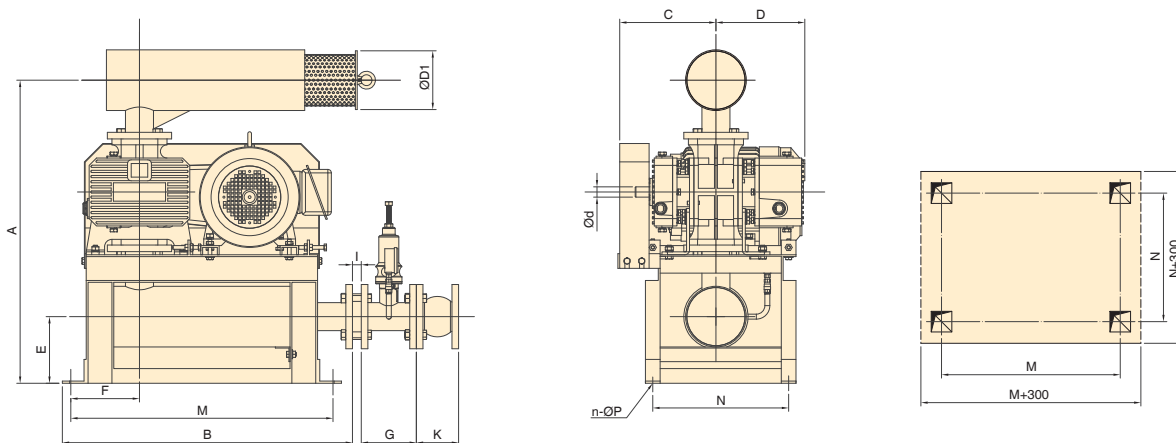

单位: Unit(mm)

型号 Type	A	B	C	D	D1	E	F	G	I	K	M	N	d	n-ØP
HRB-65	1117	865	267	242	164	226	187	150	18	115	864	530	28	4-Ø18
HRB-80	1117	864	307	282	220	206	187	180	18	135	864	530	28	4-Ø18
HRB-100	1337	1148	358	285	216	255	245	180	18	150	1144	560	38	4-Ø18
HRB-125	1337	1218	383	310	250	255	245	250	18	165	1144	560	38	4-Ø18
HRB-150	1887	1348	452	379.6	280	455	316	250	18	180	1312	835	48	4-Ø18
HRB-200	1937	1505	545	440	370	389	335	250	23	190	1378	835	55	4-Ø22
HRB-250	2023	1738	613	592	400	368	445	250	38	230	1775	835	65	4-Ø22
HRB-300	2235	2050	822	595	450	381	493	300	38	250	2020	1015	80	4-Ø22

泄压阀 Relief Valve

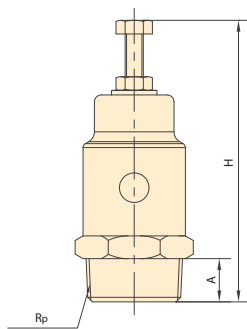

单位: Unit(mm)

型号 Type	A	H	适用机型 Application type	重量 Weight (kg)
SV1 1/4"	19	145	HRB-65, 80	0.3
SV2"	24	185	HRB-100, 125, 150	1
SV3"	30	230	HRB-200	1.6
SV4"	33	268	HRB-250, HRB-300	2.7

入口消音器 Suction silencer

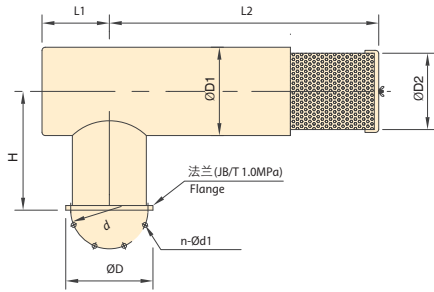

单位: Unit(mm)

型号 Type	D	n-Ød1	d	D1	D2	H	L1	L2	重量 Weight(kg)	适用型号 Application type
DN-65	180	4-Ø18	72.5	160	160	347	90	593	12.64	HRB-65
DN-80	195	8-Ø18	80	227	210	347	100	667	17.94	HRB-80
DN-100	215	8-Ø18	90	227	210	410	175	793	23.59	HRB-100
DN-125	245	8-Ø18	105	293	250	410	165	885	31.28	HRB-125
DN-150	280	8-Ø23	120	293	270	662	180	1036	42.22	HRB-150
DN-200	335	8-Ø23	147.5	400	350	698	200	1204	60.04	HRB-200
DN-250	390	12-Ø23	175	400	390	593	250	1423	77.6	HRB-250
DN-300	440	12-Ø23	200	500	450	676	250	1585	101.21	HRB-300

出口消音器 Outlet silencer

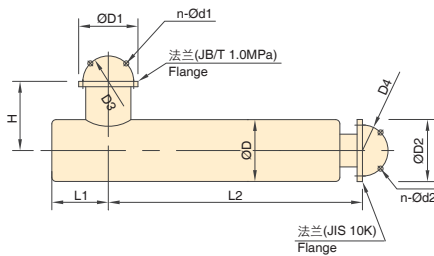

单位: Unit(mm)

型号 Type	D	D1	D2	D3	D4	L1	L2	H	n-Ød1	n-Ød2	重量 Weight(kg)	适用型号 Application type
DN-65	160	180	175	72.5	70	100	655	255	4-Ø18	4-Ø19	14.09	HRB-65
DN-80	227	195	185	80	75	100	654	275	8-Ø18	8-Ø19	19.63	HRB-80
DN-100	227	215	210	90	87.5	175	880	290	8-Ø18	8-Ø19	28.3	HRB-100
DN-125	293	245	250	105	105	205	950	290	8-Ø18	8-Ø23	38.54	HRB-125
DN-150	293	280	280	120	120	200	1005	305	8-Ø23	8-Ø23	43.38	HRB-150
DN-200	400	335	330	147.5	145	200	1170	440	8-Ø23	12-Ø23	64.46	HRB-200
DN-250	400	390	400	175	177.5	250	1255	460	12-Ø23	12-Ø25	75.9	HRB-250
DN-300	500	440	445	200	200	250	1520	550	12-Ø23	16-Ø25	107.2	HRB-300

三通管 "T"-joint

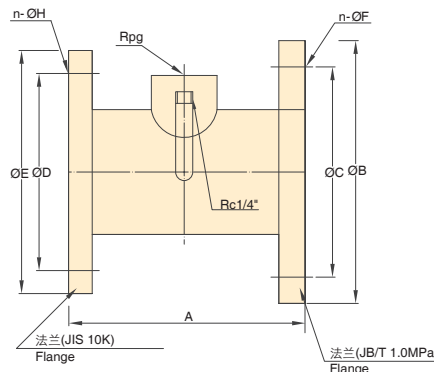

单位: Unit(mm)

型号 Type	A	B	C	n-ØF	g	E	D	n-ØH	重量 Weight(kg)	适用型号 Application type
DN-65	150	180	145	4-Ø18	1 1/4"	175	140	4-Ø19	7.5	HRB-65
DN-80	180	195	160	8-Ø18	1 1/4"	185	150	8-Ø19	9	HRB-80
DN-100	180	215	180	8-Ø18	2"	210	175	8-Ø19	11.5	HRB-100
DN-125	250	245	210	8-Ø18	2"	250	210	8-Ø23	15.5	HRB-125
DN-150	250	280	240	8-Ø23	2"	280	240	8-Ø23	18	HRB-150
DN-200	250	335	295	8-Ø23	3"	330	290	12-Ø23	23	HRB-200
DN-250	250	390	350	12-Ø23	4"	400	355	12-Ø25	30	HRB-250
DN-300	300	440	400	12-Ø23	4"	445	400	16-Ø25	45	HRB-300



地脚螺栓 Anchor bolt

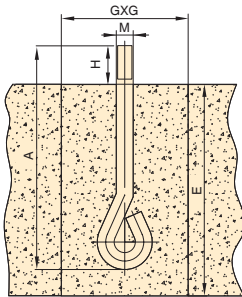

单位: Unit(mm)

地脚螺栓M Anchor bolt GB799-88	A	H	E	G×G	适用型号 Application type
M12	160	36	224	100×100	HRB-65, 80
M16	220	45	275	120×120	HRB-100, 125, 150
M20	300	55	345	150×150	HRB-200, 250, 300

注: 1. 图注E为最小尺寸, 根据安装的土壤情况, 应适当加深。
2. G×G为二次浇灌前的预留孔尺寸。

Note: 1. The note E on the drawing is the minimum size, it shall be deepened properly according to the soil condition in the installation place.
2. G×G is the size of the preformed holes for the secondary casting.

弹性接头 Flexible connector

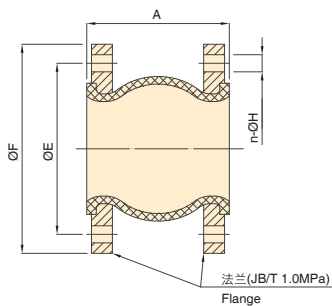

单位: Unit(mm)

型号 Type	A	E	F	n-ØH	重量 Weight (kg)	适用型号 Application type
KXT65	115	145	180	4-Ø18	4.68	HRB-65
KXT80	135	160	195	8-Ø18	5.5	HRB-80
KXT100	150	180	215	8-Ø18	6.7	HRB-100
KXT125	165	210	245	8-Ø18	8.3	HRB-125
KXT150	180	240	280	8-Ø23	12	HRB-150
KXT200	190	295	335	8-Ø23	14	HRB-200
KXT250	230	350	390	12-Ø23	18.6	HRB-250
KXT300	250	400	440	12-Ø23	27.5	HRB-300

逆止阀 Check valve

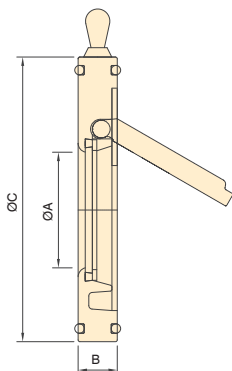

单位: Unit(mm)

型号 Type	A	B	C	重量 Weight (kg)	适用型号 Application type
DCV-65	45	18	122.5	1.4	HRB-65
DCV-80	52	22	132	0.8	HRB-80
DCV-100	65	22	158	0.9	HRB-100
DCV-125	90	22	190	1.2	HRB-125
DCV-150	115	22	215	1.5	HRB-150
DCV-200	160	25	268	2.6	HRB-200
DCV-250	180	38	325	12.5	HRB-250
DCV-300	213	38	375	18.5	HRB-300

用途说明 Applications

水处理
Water treatment

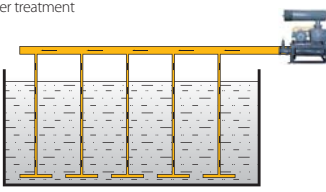

1 用于污水处理厂的曝气处理
Aeration of sewage

燃烧炉
Incinerator

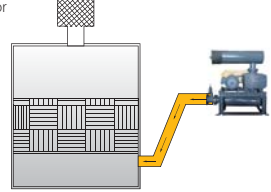

5 用于助燃，增加氧气促进燃烧
Used for combustion, increasing oxygen to promote combustion

管路清理
Pipe clearing

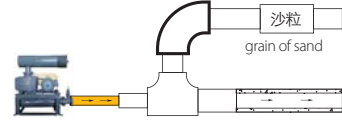

9 通过气体吹动沙子或硬质颗粒来冲刷管路
Use gas blowing sand to flush pipes

啤酒厂、饮料行业
Brewery and beverage industry

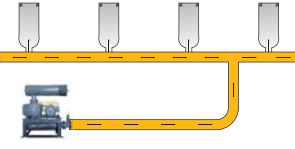

2 用于气体运动将瓶内死角清理干净
Clean up the bottle's dead angle by gas

发酵厂
Fermenting plant

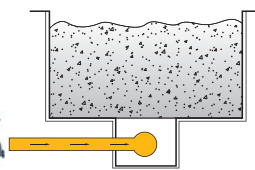

6 通过增加含氧量，来促进发酵
Increasing oxygen to promote the fermentation

电镀行业
Electroplate factory

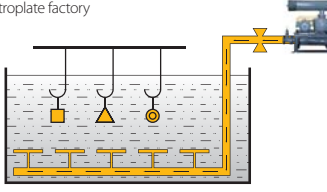

10 利用气体使液体均匀化，液体与工件充分接触
Stir gas liquid, make its uniformity

喷涂
Spray finishing

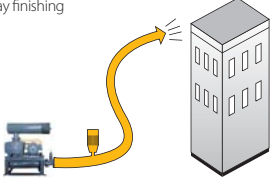

3 通过气体将防火材料喷涂到墙上或钢筋结构上
Use gas spraying fire-resistant material on the wall

洗车
Car washing



7 洗车厂通过虹吸现象带动洗车液清洗车辆
Use washing fluid washing car base on siphon principle

桑拿
Sauna

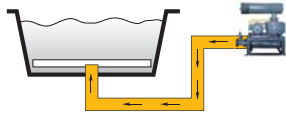

11 做人体按摩，促进血液循环
Do body massage, promote the blood circulation

养殖场
Fishery

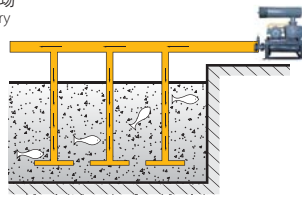

4 养殖场中增加水中氧气
Increasing oxygen in water

造纸厂
Paper mill

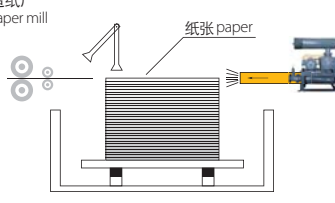

8 纸张被吹起后，机械手臂使其搬运
The mechanical arm carries the paper after it has been risen by the wind

物料输送
Conveying

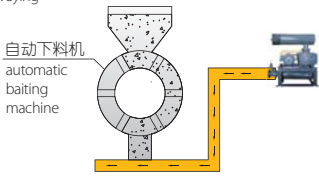

12 利用气体运动将物料输送
Use gas conveying materials



欢迎索取以下产品型录



泵系列

- 潜水泵系列
- 陆上泵系列
- 特种泵系列
- 消防泵系列



搅拌推流系列

- 搅拌机系列
- 推流器系列



供氧曝气系列

- 曝气机系列
- 曝气盘系列
- 曝气管系列



风机系列

- 三叶罗茨鼓风机系列
- 增压罗茨鼓风机系列
- 沉水式风机系列



污泥处理设备 及其他

- 固液分离系列
- 泡药设备
- 输送设备



川源（中国）机械有限公司
GSD Industrial Co.,Ltd.

免费咨询电话

400-657-9066

本型录内容如有变更，恕不另行通知。
We reserve the right to change content without notice.

CY-G7

