

GSD INDUSTRIAL CO., LTD.



RCT

散气管



川源股份有限公司



用途

1. 都市下水道污水处理系统。
2. 各类型工业污水处理。
3. 各类型废水臭氧之扩散。
4. 稳定淤渣。
5. 养殖鱼池之曝气。
6. 河川湖泊之曝气。

APPLICATIONS

1. Municipal sewage, waste water treatment system.
2. All kinds of industrial wastewater treatment.
3. Ozone diffuse of different wastewater.
4. Sludge stabilization.
5. Aeration in aquafarm.
6. Aeration of purify, rivers and lakes water.

结构特点

1. 膜片使用EPDM工程复合橡胶制，具有抗UV、耐酸碱、耐腐蚀的特性，在各种废水曝气环境中，可达到长期使用的目的。
2. 利用中空设计消除浮力。
3. 压铸一体成型之空气入口。
4. 本体支撑结构采PVC管。
5. 本体和曝气膜片采用SUS304夹具固定。
6. RTC1000曝气膜片表面微孔高达30,000个。

FEATURES

1. We manufacture our RCT tube diffuser with compression molded EPDM membranes to avoid ultraviolet degradation, acid and alkali or chemical corruption. So the diffuser could be used for a long time.
2. Using hollow design eliminates buoyancy.
3. The air-entrance is integrated using die-casting.
4. The body support are made of PVC pipes.
5. We use SUS 304 clamp to fix membranes on PVC pipes.
6. The quantity of micropore which locate in the RTC1000 membrane surface is up to 30,000.

优点

1. 传氧效率高。
2. 有效防止堵塞，具自动清除功能，可有效防止污水逆流。
3. 曝气面积大。
4. 压力损失小。
5. 容易安装。
6. 间歇操作能力强。
7. 曝气膜片具有高的抗变形性及抗撕裂指数。

ADVANTAGES

1. High oxygen transfer efficiency.
2. Effectively avoid walling up, with automatic clearance function and prevent the backwash of the wastewater effectually.
3. Large service area.
4. low headloss.
5. Easy to install.
6. High ability of intermittent operation.
7. The membrane has high non-deformability and anti-tearing index.

主件参数

1. 材料: 三元乙丙橡胶(EPDM)
2. 厚度: 2.0mm±0.15mm
3. 抗拉强度: 10.34MPa(ASTM D412)
4. 最大展延度: >600%(ASTM D412)
5. 抗撕裂强度: >30kgf/cm²(ASTM D624 Die c)
6. 硬度: 55±5邵尔A (ASTM D2240)
7. 开孔尺寸: 1mm

MASTER PART PARAMETERS

1. Material: ethylene propylene diene monomer (EPDM)
2. Thickness: 2.0mm ± 0.15mm
3. Tensile strength: 10.34MPa(ASTM D412)
4. Maximum extensibility: >600%(ASTM D412)
5. Tearing toughness: >30kgf/cm²(ASTM D624 Die c)
6. Rigidity: 55±5 Shore A (ASTM D2240)
7. Starter size: 1mm

性能参数 PERFORMANCE PARAMETERS

型号 Type	材质 material			通气量 Air flow (m ³ /h)	气泡直径 Bubble diameter (mm)	有效面积 Service area (m ²)	重量 Weight (kg)	操作温度 Operation temperature (°C)
	膜片 Membrane	支撑管 Membrane support	管束 Membrane cup					
RCT-600	EPDM	PVC	SUS304	2~15	1~2	0.102	0.9	<70
RCT-1000	EPDM	PVC	SUS304	2.4~19.2	1~2	0.15	1.4	<70

氧利用率曲线 OTE CURVE

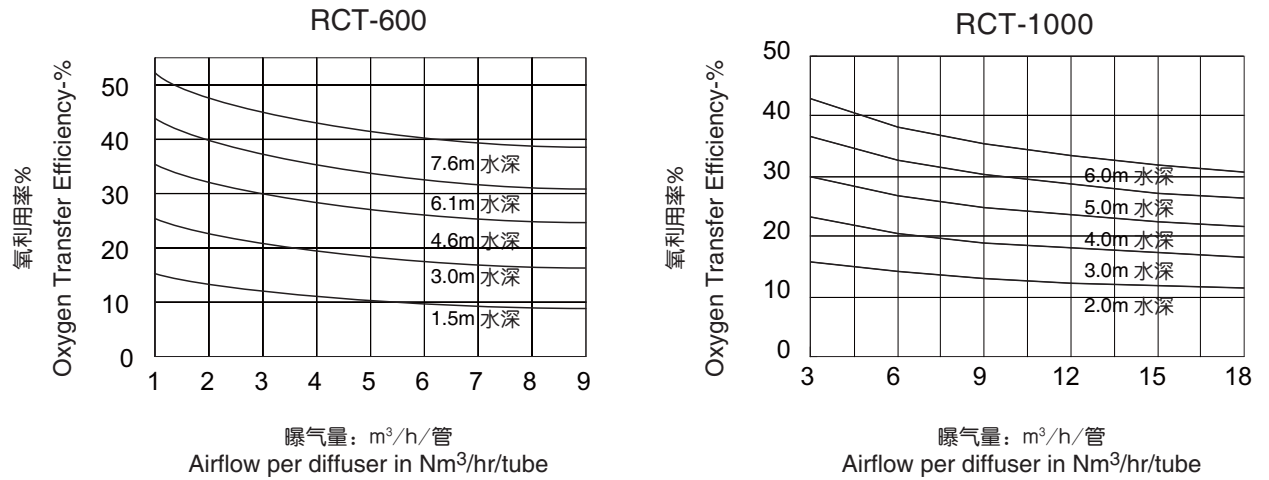

压损曲线 HEADLOSS CURVE

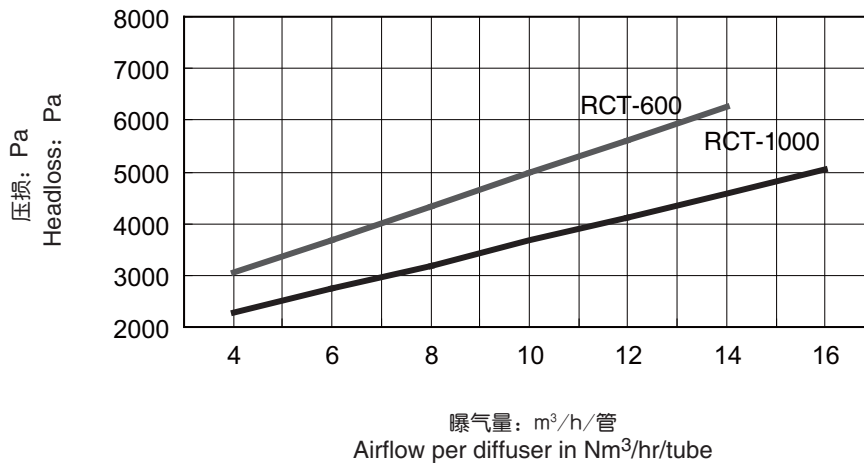

安装示意图 SCHEME OF INSTALLATION

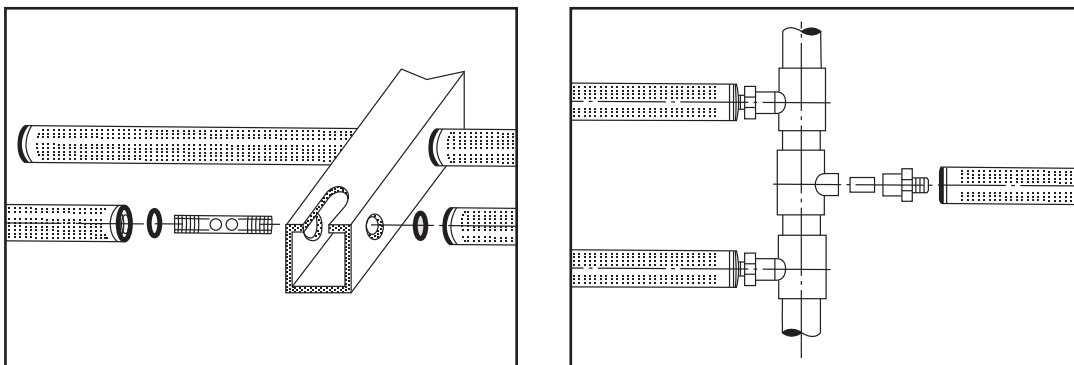

结构图 CONSTRUCTION

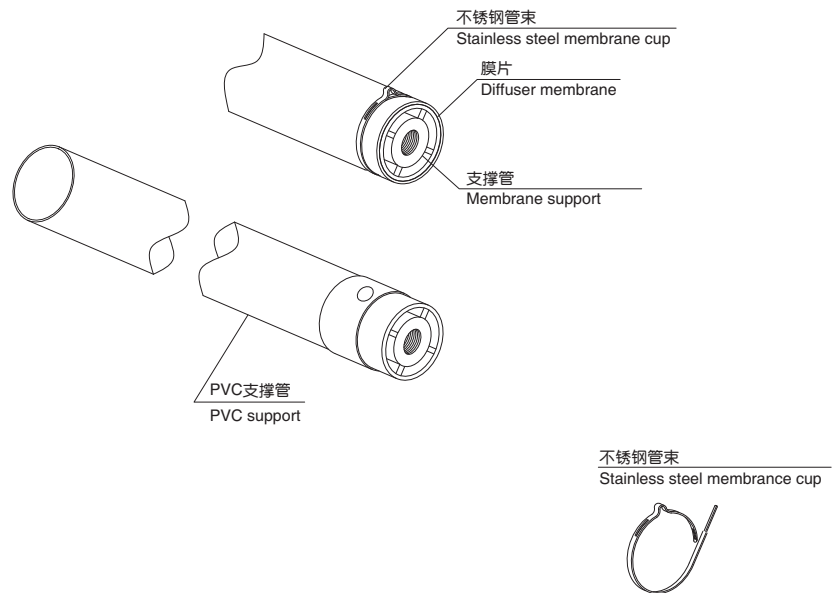

安装方式 INSTALLATION

